

# FANTASY™

No. 4  
\$3.00  
£1.50

## Modeling

**WHITTEN'S  
WIZARDRY**

**ROCKET AERIAL  
PHOTOGRAPHY**

**BOWER'S GIRLS**

**EXAMINING  
THE EMPIRE'S  
VEHICLES:  
THE  
SNOWWALKER  
AND THE  
SNOWSPEDER**

**A VISIT TO  
RAL PARTHA**

**ROLES PEOPLE  
PLAY**

**AMERICA'S  
PREMIERE  
COMPETITION**





**STARLOG PRESENTS**  
**THE BROTHERS**  
**HILDEBRANDT'S**  
**ATLANTIS**

**1982 Calendar**

**13 Original Paintings**

ATLANTIS: The Lost Continent. It has been the object of romantic fantasies for centuries. Now the renowned art team, *The Brothers Hildebrandt*, have created what could well be the most fantastic interpretation of this mythical land: *The Brothers Hildebrandt ATLANTIS 1982 Calendar*.

With thirteen original full-color paintings plus small black-and-white sketches, ATLANTIS comes alive with dinosaurs, beautiful heroines and sleek spaceships—a mystical blending of technology and simplicity in the artistic style that belongs only to the Hildebrandt's.

From their famous *Star Wars* poster, to the illustrations for the *Sword of Shanarra*, to their own illustrated novel, *Urshurak*—the *Brothers Hildebrandt* have become the most influential force on the science fiction and fantasy art scene. But it was their three J.R.R. Tolkien calendars that brought the Brothers their international following.

Starlog Press, the leading publisher of science fiction and fantasy, is proud to premiere the *Brothers Hildebrandt's* newest calendar, destined to become as legendary as Atlantis itself. This is more than simply a collector's item; it is an art treasure and a journey into fantasies limited in scope only by human imagination. Join Starlog Press and the *Brothers Hildebrandt* on this epic search.

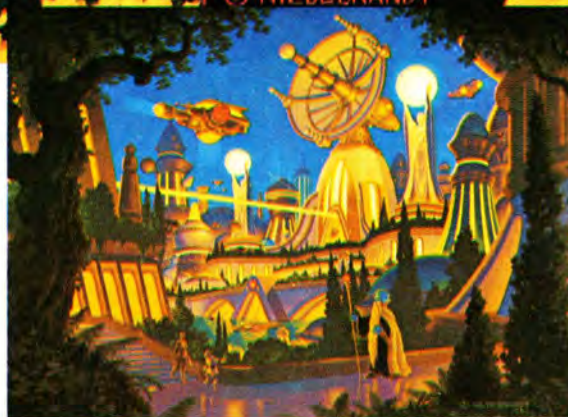

**ORDER YOUR HILDEBRANDT "ATLANTIS" CALENDAR NOW!  
 ONLY \$7.95**

Send to:  
**STARLOG PRESS**  
**HILDEBRANDT "ATLANTIS" CALENDAR**  
**475 Park Avenue South**  
**New York, NY 10016**

NAME (Please print clearly)

ADDRESS

CITY

STATE

ZIP

I'm ordering \_\_\_\_\_ "ATLANTIS"  
 calendars at \$7.95 each . . . . . \$ \_\_\_\_\_  
 Postage at \$1.50 each \$ \_\_\_\_\_  
**TOTAL ENCLOSED: \$ \_\_\_\_\_**

Foreign customers add \$4.06 for each calendar ordered, surface rate postage.  
 Please allow 4 to 6 weeks for delivery of 3rd class mail.  
 First class delivery usually takes 2 to 3 weeks.  
 ONLY U.S., Australian and New Zealand funds accepted. **DEPT. FM4**

# FANTASY

## Modeling

VOLUME FOUR



PHOTOS: LANE STEWART

**Inspired by the Osprey book on the Mongols Phil Bracco created this vignette.**

<b>5</b>	EDITORIAL	Philip O. Stearns
<b>6</b>	WILLY WHITTEN'S WIZARDRY	Willy Whitten
<b>15</b>	MODEL GIRL	Martin J. Bower
<b>18</b>	THE ESB SNOW WALKER	Andrew P. Yanchus
<b>22</b>	THE ESB SNOW SPEEDER	Jeff Pollizzotto
<b>26</b>	RAL PARTHA EXPOSED	Philip O. Stearns
<b>32</b>	ROLE PLAYING GAMES	Mike Kilbert
<b>38</b>	AERIAL PHOTOGRAPHY AND ROCKETS	Michael A. Banks
<b>42</b>	AMERICA'S PREMIERE COMPETITION	Philip O. Stearns
<b>45</b>	COLLECTABLES	
<b>49</b>	BOOK REVIEWS	
<b>50</b>	ODDS AND ENDS	Andrew P. Yanchus



The forest, now in shadow, would soon be black with night. The wanderer, weary from her plight, anxiously searched for a resting ground, unaware that the "CHILDREN OF THE NIGHT" lurked nearby. The unexplained screams of doom and dread came upon her, without warning. The terror of the night was unfolding . . .

- |                                 |                             |
|---------------------------------|-----------------------------|
| 13-001 Small Cold Drake         | 13-009 Voodoo Man Set       |
| 13-002 Hill Giant               | 13-010 Insect Men Warriors  |
| 13-003 Trolls (set 1)           | 13-011 Lesser Demons        |
| 13-004 Small Carnosaurs (set 1) | 13-012 Manticore            |
| 13-005 Megalosaurus             | 13-013 Were Creatures       |
| 13-006 Monoclonius Agathaumas   | 13-014 Slimes and Jellies   |
| 13-007 Victims                  | 13-015 Thieves              |
| 13-008 Vampire Lord Set         | 13-016 Shadow Elf Sorcerors |

The "Children of the Night" have been turned loose on the world. They're lurking at your local adventure gaming store.

**RAL PARHTA**

5938 CARTHAGE CT. • CINCINNATI, OHIO 45212

# FANTASY Modeling

VOLUME FOUR

## Publisher

RITA EISENSTEIN

## Editor

PHILIP O. STEARNS

## Creative Director

CHEH N. LOW

## Associate Editor

RICHARD K. RIEHN

## Contributing Editors

MICHAEL KILBERT

ANDREW YANCHUS

## Managing Editor

STUART MATRANGA

## Associate Art Director

BOB SEFCIK

## Art Staff

LAURA O'BRIEN

## Photographer

JOHN CLAYTON

For Advertising Information:  
Rita Eisenstein (212) 689-2830

### ABOUT THE COVER:

Lane Stewart's cover photograph taken at the Military Miniature Figure Collectors of America annual competitions shows Murray Richter's 1/60 scale Robot figure by Bandai from *Gundan*, a Japanese TV series.

FANTASY MODELING is published by FANTASY MODELING INC. 475 Park Avenue South, New York, N.Y. 10016. This is VOLUME FOUR. Content is © Copyright 1981 by FANTASY MODELING INC. All rights reserved. Reprint or reproduction in part or in whole without written permission from the publishers is strictly forbidden. FANTASY MODELING accepts no responsibility for unsolicited manuscripts, photos, art, or other materials, but if freelance submittals are accompanied by a self-addressed, stamped envelope, they will be seriously considered and, if necessary, returned. Products advertised are not necessarily endorsed by FANTASY MODELING, and any views expressed in editorial copy are not necessarily those of FANTASY MODELING. Subscription rates: \$8.99 one year (4 issues) delivered in U.S. and Canada, foreign subscriptions \$11.39 in U.S. funds only. New subscriptions send directly to FANTASY MODELING, 475 Park Avenue South, New York, NY 10016. Notification of change of address or renewals send to FANTASY MODELING Subscription Dept. P.O. Box 142, Mt. Morris, IL 61054. Printed in U.S.A.

# EDITORIAL



PHOTO: JOHN CLAYTON

Steven Sippin and Kevin Smyth's space cruiser is depicted in low Earth orbit prior to re-entry.

It is almost impossible to believe that here we are with our fourth edition of FANTASY MODELING. It seems that only yesterday we were rushing about with issue Number one. What it really means is that one year has already sped by and we are now entering the second year of production. Looking back at the past, what have we learned? Well, first by your overwhelming support we have found out that our original idea to enter into the fantasy field was certainly a valid one. Our continually rising circulation with each new issue attests to this. We have also learned about your general likes and dislikes. Again, a pattern is gradually establishing itself in this direction. It has been our policy to find for you new artists and writers with each issue and we will continue on this path in an effort to bring you expertise from all parts of the globe. Also, by covering various national and international competitions we are able to contact some of the most undiscovered modelers as well as the masters in the fantasy area and bring their work to you. By exposing their work in the magazine we are encouraging many more modelers to submit their creations so that they may be shared by all of you. In the coming year FANTASY MODELING is preparing its own awards which we will be presenting at all the major competitions. These

are being designed by sculptor Bill Merklein and we think you will find them very attractive indeed. All in all what we are trying to do here at the magazine is to promote every aspect in the fantasy and sci-fi worlds of modeling and gaming for your enjoyment. To this let us tell you a bit about this issue.

Martin Bower, that eminent creator of space ships and model ladies for films and television, gives us an intimate view of his methods and a couple of fabulous examples of his female creations. Willy Whitten, another film-involved artist, who creates all manners of incredible pieces, brings us a space lab and alien creatures and lets us in on his working principles. Michael Banks discusses the added thrills of doing your own aerial photography from your backyard rocket ship. We are also including a fascinating visit with Glenn Kidd and Tom Meyers at Ral Partha who give you some of the most intricate and beautiful 25mm figures ever created. Mike Kilbert discusses most of the Role Playing Games available, while Andy Yanckus and Jeff Pollizzotto tell you how to super detail the *Empire Strikes Back* Snow Walker and Snow Speeder with some very effective touches. We hope that this potpourri of modeling know-how will whet your appetites for fantasy creations until our next issue. ▲

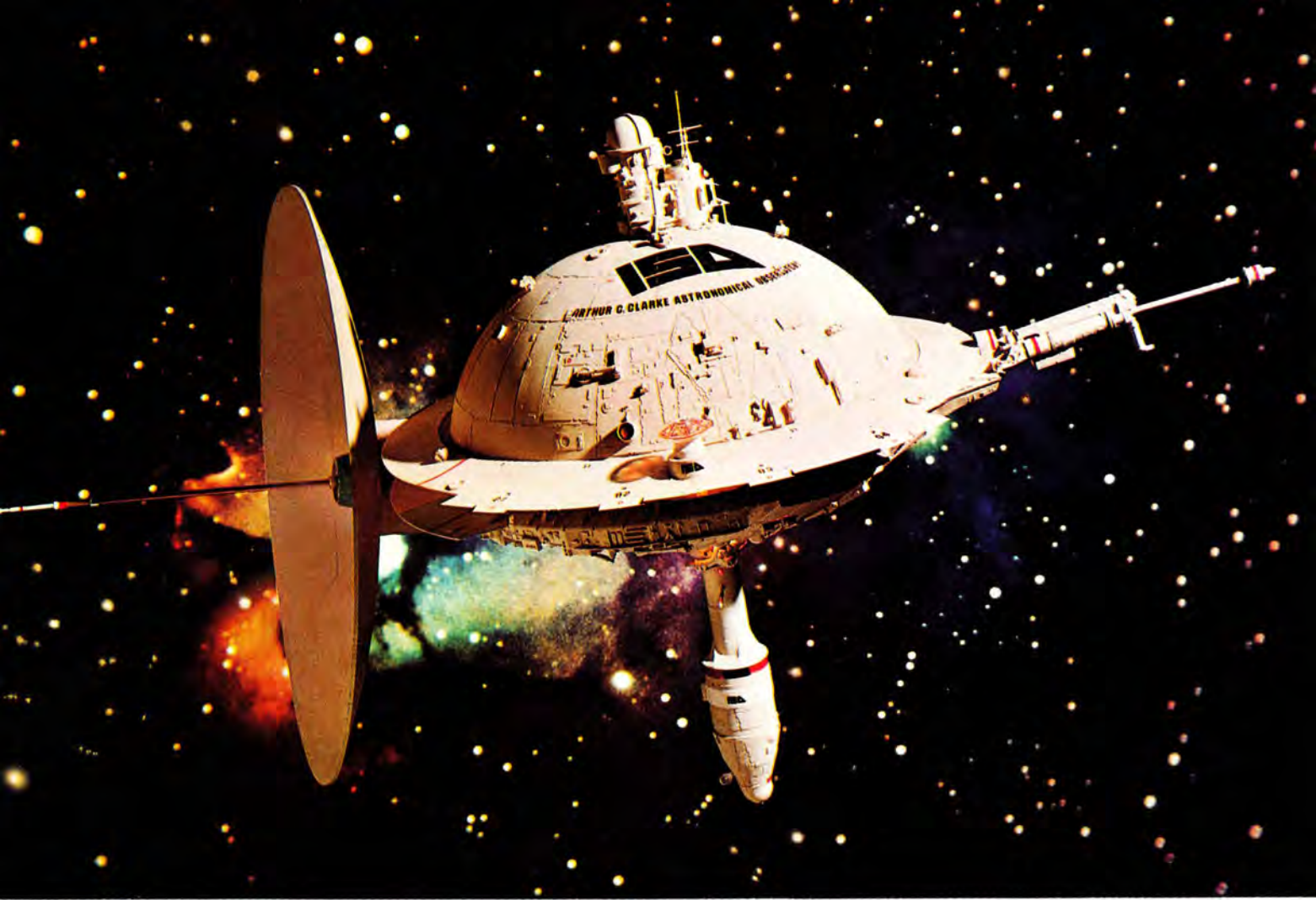

## The Wizardry of Willy Whitten

# STARLAB MINIATURE

By WILLIAM D. WHITTEN

**I**n September of 1979, I received a phone call from Steve Brown, Art Director at J.B. Talmadge & Company, who was handling the art and advertising for Watermark's *Alien Worlds* radio show. They were interested in producing a brochure for the program and were considering the idea of using a model with special effects photography, rather than paintings and illustrations, as they had used in the past.

Steve asked me if I thought it was possible to produce a model on their proposed budget and if I would be interested in doing so. I found the idea exciting and felt that it could be done.

In a round-table discussion with Steve, the Watermark people, and myself, we came upon a design direction. I went back to my studio to sketch "thumbnails" of these design ideas.

The beginning of a long process.

Another meeting was held to choose from these designs. They then requested a finished sketch of the final design, which I submitted a couple of days later as a rendering in acrylic on illustration board (enclosed). We all agreed to the design and determined that the model had to be built in such a way as to make it a finished photography model in three separate modes, to simulate it having been constructed in stages in outer space.

### CONSTRUCTION OF THE MODEL

#### Materials

Three plexi-glass domes served as the basic shapes of the structure; a six inch deep, twelve inch diameter dome for the upper portion, a three inch

deep, twelve inch diameter bowl for the lower portion, and a two inch deep, seventeen inch diameter dish for the radio telescope.

Other materials were: a 1½ inch diameter plexi-glass tube, a 3 inch diameter plexi-glass tube, a ⅞ inch diameter brass tube, styrene sheet plastic of various thicknesses, small shapes and parts from model kits, Pactra camouflage gray spray paint, Primer spray, liquid latex, Perma-bound Superglue, Testor's plastic cement, Squadron Green Putty, Rub-on type (letters), striping tape, masking tape, string, opticle fiber, 60-watt light bulb and socket, grain of wheat bulbs.

**Above: Whitten's completed Starlab hovers in the cosmos. Opposite Page: Another creation hollers on the heath.**

## Tools

Hobby vice, needle-nosed pliers, exacto knife, scissors, miniature file set, allen wrench, hole punch, tweezers, palm drill, "C" clamps, sandpaper, fine sanding film, pointed scribing tool (sculptor's awl).

## PHASE I

### Section A on Exploded View

I decided to light the model, using an optical fiber, so my first consideration was the interior light source. This obviously had to be contained in Phase I. I took the three inch deep plexi-glass bowl and drilled a hole in the bottom and mounted a normal sized lamp socket on an angle inside.

Next, a sheet of  $\frac{1}{8}$  inch styrene sheet plastic was used to construct a "lid" for the bowl (See Figure 2).

Nail and String Compass:

For making large circles you can construct a compass using kite string and a nail. First find the center on your material by measuring out a square about 4 inches larger than the circle is to be, and drawing an "X" from the angle of each corner. The center of the "X" is the center of the square. Lay the material on a larger piece of plywood and drive a nail through the center; not too deep, just enough to secure it. With most plastics it is a good idea to drill a hole just slightly smaller than the breadth of the nail. Now, make a loop of string the length of your radius. Stretch this loop from the center nail to an etching or marking tool at the radial end. You can now draw or etch your circle, using the taut string as a guide. Note: Do not "tie" the string to your nail or tool unless you want to etch tight spirals, rather let it act as a smooth gear.

Using this method I etched a twelve inch circle in the styrene and pulled a disc out of the square. With a minimum of sanding this fit snugly on top of the plexi-bowl (See Figure 3A). I then cut out a second disc. With a grease pencil I subdivided the second disc. (Often a smaller circle, offset within a larger one lends a mechanical, or technological, look to design.) I used this motif as a starting point. I then subdivided the remaining area with radial lines which cross-hatched with the offset circular design (See Figure 3B). I made paper patterns by tracing the guidelines on the styrene disc. Then I cut differing thicknesses of styrene sheet, using these patterns as guides, but cutting them  $\frac{1}{16}$  inch smaller all the way around. That way I could create a  $\frac{1}{8}$  inch gap between the separate shapes to enhance the "plating" effect I

desired. These were then glued to the plate. Because the "porch" overhand had to extend farther (I did not have a sheet of styrene large enough to cut a sixteen inch circle from) I had to draw out a twelve inch diameter circle within a sixteen inch diameter circle on a large sheet of matteboard. With this I had the template for the extra two inch ring to add to the twelve inch disc (See Figure 5) Six separate plates of styrene were cut to be assembled into this extension. I now had a sixteen inch disc with some plating forms in the inner twelve inch circle. I added a band of styrene strip ( $\frac{1}{4}$  inch) around the twelve inch circumference. With this band glued in place, I fashioned a cover plating for the "porch roof" (See Figure 6). Paper thin styrene sheet was used for this.

Next, I glued four styrene blocks inside the bowl to act as mounts for the first 12 inch disc. I then drilled holes through the disc into these mounting blocks and used screws to attach the disc onto the bowl. With the nail and thread I measured an eleven inch circle onto the disc. I then cut  $1\frac{1}{2}$  inch high pieces of  $\frac{1}{16}$  inch styrene, eight inches long. Using needle-nosed

pliers, I dipped these into boiling water to curve them to match the arc of this eleven inch circle (a hit and miss operation). At this point, I came upon an enlightening idea that worked fairly well. By drilling small holes in an inverted "V" pattern on one of these curved plates and then drilling a line vertically to meet the tip of the "V," I could create a false perspective landing light pattern that seemingly went into the heart of the space station. (Fiber optics were added at a later point.) I now glued on several of these warped styrene shapes, staggering them along the eleven inch circular plane and backing them with pre-constructed boxes of the same height ( $1\frac{1}{2}$  inch). I could now place the sixteen inch dish on top of this, creating an enclosed structure.

I now fashioned the lower "porch" structure (see Figures 7 & 8), duplicating the upper section part of the way around. However, I ad-libbed structurally where the Landing Bays were to be (01, 02, 03, 04). Having my basic Phase I structure worked out, it was now ready to be dressed with styrene plating and detail shapes. (See Figures 9A and 9B).



**The Control Tower**

The control tower is constructed out of two clear plastic caps glued together at their rims. A hole was drilled in the "bottom" cap (to allow for a grain of wheat bulb to be mounted inside). This was mounted on a series of squat styrene tubes (See Figure 10). This tube structure was then mounted onto a specially cut lip plate on the rim (See Figure 10B).

**Section B on Exploded View**

This piece is basically a piece of cop-

per tubing "dressed" with various scratch built and styrene parts.

**PHASE II**

To make the lower module I cut a four inch length of one inch diameter plexi-glass tube and a two inch length of two inch diameter tube. Next I cut a two inch diameter disc from fairly thick (about 1/8 inch) styrene sheet. (This served as the joint for the different sized tubes to meet—see Figure 11.)

Styrene mini-domes or "caps" were

made by heating the center of a sheet of plastic and then stretching it over round metal objects.

NOTE: The trick to knowing when to stretch is to hold the sheet over the flame just until the center of it begins to sag (ever so slightly). Also you must move quickly once the plastic has softened (See Figure 13).

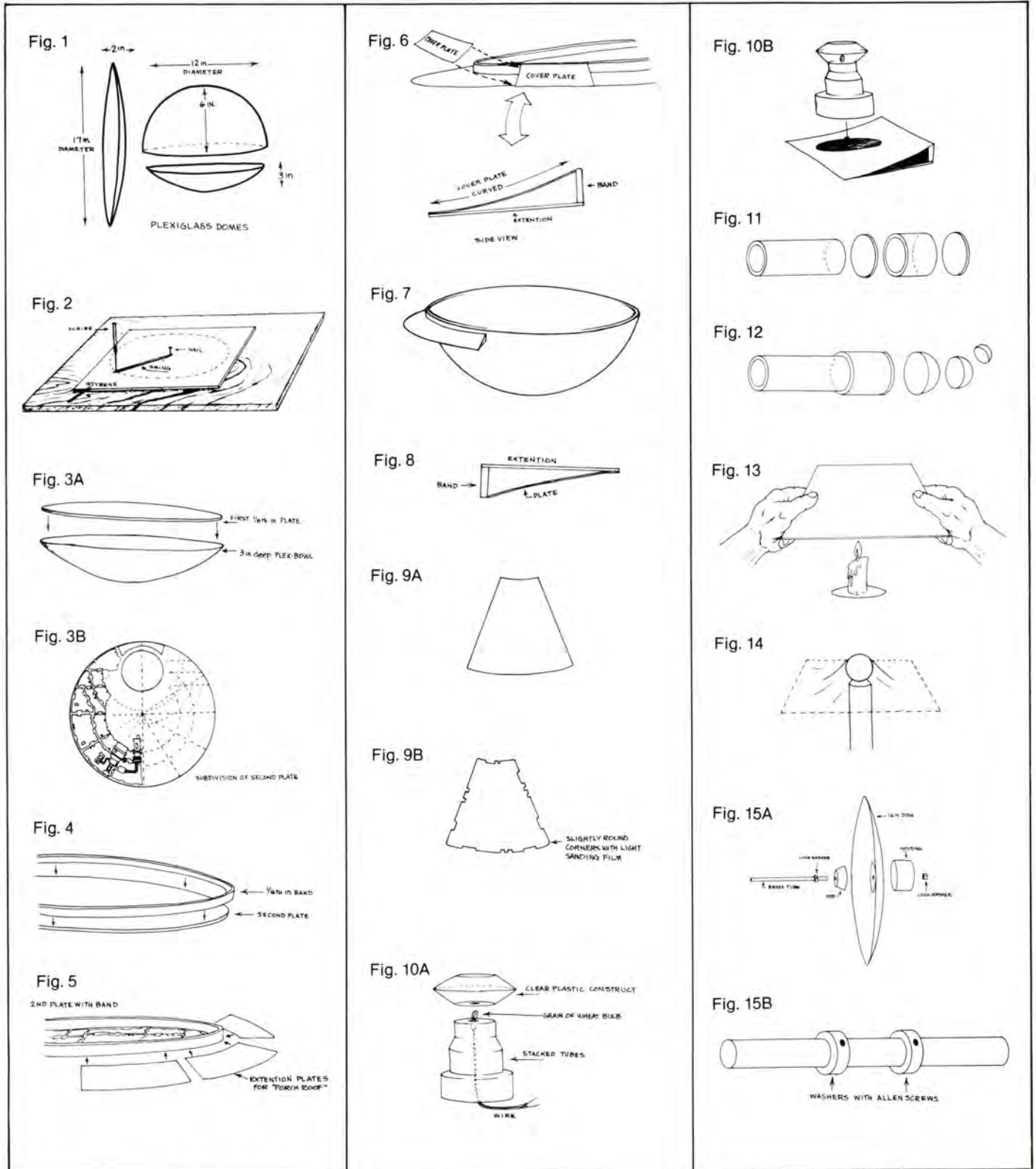

Before these pieces were assembled, I mounted the optical fiber. To create a lens tip, hold a cigarette to the tip (do not touch it to the tip, just hold it closely). To drill surface holes for mounting optical fibers, the drill bit should be the same breadth as the fiber.

The seams where the cups meet was then given a layer of filler putty and sanded (squadron green putty would be best here). After I had the basic form, I then plated it with styrene plates, bands and objects. Again, avoid symmetry (as a general rule) in this sort of molding because the asymmetry lends a character akin to larger structures.

### PHASE III

The last stage consists of the main dome structure, the observatory buttresses atop that, and the large radio telescope dish.

#### Main Dome

The first problem to be tackled is the curvature of the plating planes on the main dome. I had ad-libbed the bottom bowl during the plating stage; but on the upper dome the curvature is much more pronounced (complete half-sphere). For the radial lines to look proper, they had to conform properly to the true planes of the dome.

I set the dome upside down on a pot stand and measured the height of the edge of the dome, aligning it so that it was equal all the way around. With the dome now level, I dropped in a B.B. and marked where it came to rest. This was my approximate "center," or top of the dome. A hole was then drilled at this point. It was then turned upright and set on two boxes of equal height. I tied nails to each end of a length of string. By putting one nail into the hole in the dome and allowing the string to drape over the dome, the other nail acting as plum weight, I was able to find my vertical planes. The horizontal planes were marked with the same string by tying loose knots at measured lengths. Push the point of a grease pencil through the loop in the knot and follow the string around the surface of the dome. With these planes drawn out on the dome, I began cutting approximate shapes out of styrene sheets. Then, by putting the dome over a light and laying these shapes over the dome, I was able to see the plane lines through the thin styrene. I could then trace the curvature onto the flat styrene. The sheet was recut to the curvature lines, formed and filed. After this "patchwork" of plating was applied, I began adding small shapes simulating machinery, access hatches, etc.

The observation towers and telescope housing on top of the dome are simply two sections of plexi-tube

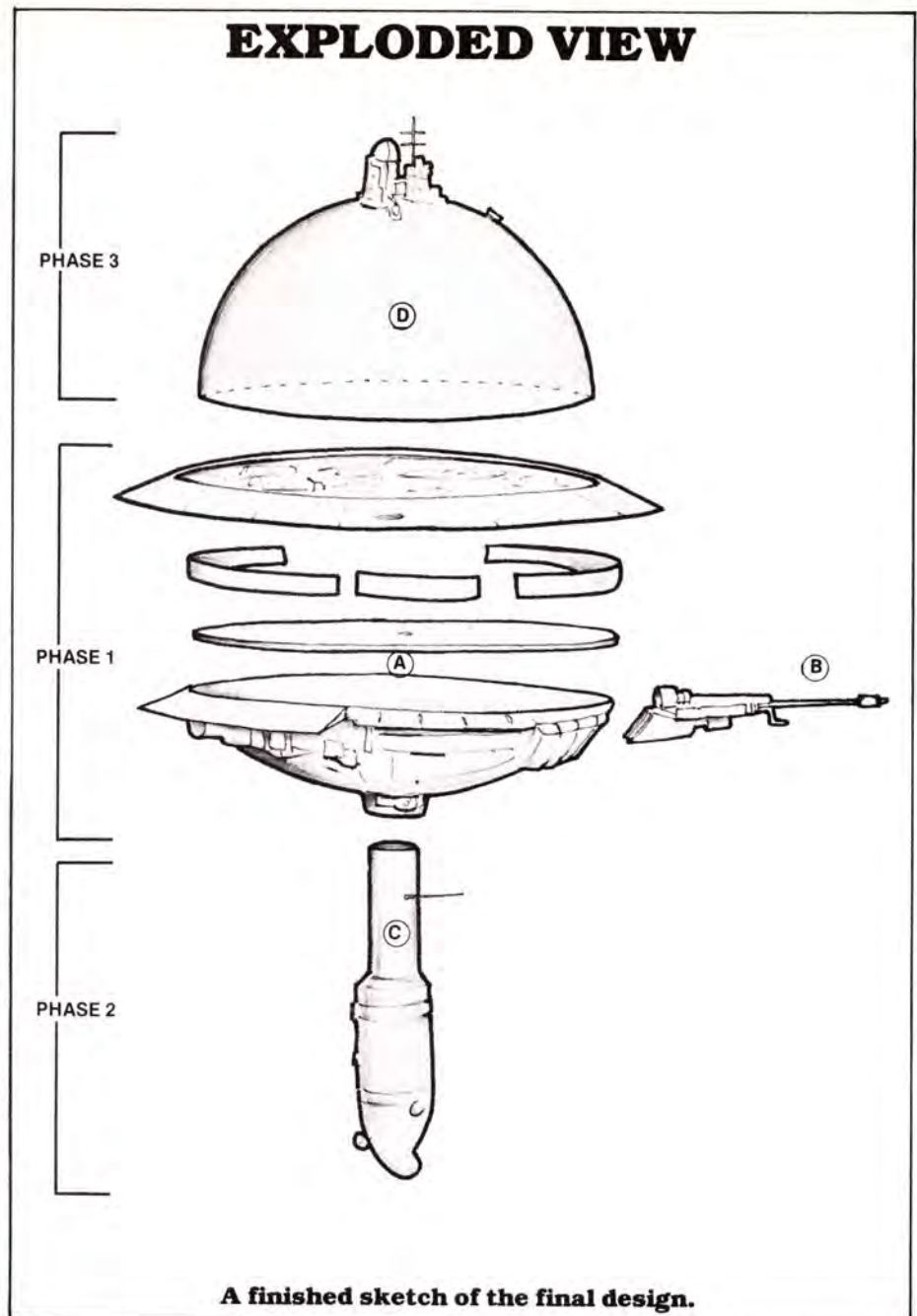

A finished sketch of the final design.

dressed with ad-lib shapes. The observatory dome is sheet styrene, heat stretched over a smooth ball (See Figure 13), with a band of strip styrene wrapped over the top.

#### Radio Antenna Dish

A  $\frac{5}{8}$  inch hole was drilled into the center of the sixteen inch plexi-dish. Through this I mounted a  $\frac{5}{8}$  inch wide, twelve inch long brass tube. The hub was built from stacked styrene disks, which were filed and sanded to shape. The housing on the rear is a three inch portion of plexi-tubing. The hub and housing were glued to the dish (See Figure 15A). The brass tube was then attached, using metal washers with allen screw locks (See Figure 15B). At the top of the brass tube I mounted a styrene axle joint from a truck kit. The inside of the dish was also plated with styrene shapes in a "fanlike" design.

#### Painting the Model

As the model was to be a representation of a newly built space station, there was no need for weathering. There is no weather in outer space, of course.

I simply sprayed the structure with Pactra camouflage gray. I masked the optical fiber tips with a dot of liquid latex to avoid painting them.

All of the lettering is rub-type. There are several companies that sell kits for creating your own rub-type, which is an excellent way to make logos and other "hard to handpaint" designs for models. Also, there is a myriad of styles of type available at art stores and some electronic stores.

#### Photography

The model was mounted in front of a rear projection screen and photographed by Robert Wortham.

## A WORD ABOUT SCULPEY

By WILLIAM D. WHITTEN

**T**here are several characteristics about Polyform (Sculpey) that make it the ideal medium for sculpting miniature figures. The most important is that it can be hardened at any point during modeling by baking (usually only 5 or 10 minutes for small pieces). You can then add soft sculpey onto the hardened model and continue modeling. The advantage of this is obvious to anyone who has sculpted, say, a face that is "just right" and then smudged it while trying to attach it to the body.

I will quote from the package it comes in and comment:

"Sculpey bakes permanently hard in your home oven, 15-30 minutes at 325°F"—*For small pieces I find that baking for about 10 minutes at 275° is best, especially if you plan to add to the piece.*

"Sculpey stays pliable indefinitely, until baked."—*I have had one box of this stuff last 7 years and still it remained sculptable. And yet, I have found a few boxes of "crumbly" sculpey fresh from the store. Generally speaking, this claim is true.*

"It will not shrink. Can be used over armatures."—*Yes, rather than wasting large amounts of sculpey using it as a "finishing*

*layer" over forms of wood, wire, styrofoam or any material that can withstand the baking heat is advisable.*

"Sand it, carve it, add to or make corrections, then it can be baked again."—*This is it's most advantageous feature.*

"Paint it! Water based acrylics work best."—*Don't apply enamel based paints to sculpey; it will remain forever tacky.*

I first discovered this modeling compound many years ago. At that time it was called "Polyform" and came in a "matter of fact" looking package. For marketing reasons, I suppose, the Polyform Company changed the name to "Sculpey" and began packaging it in the unfortunate box with brightly colored, childlike illustrations. This has had the effect of turning some serious sculptors from discovering the wonders inside. But, I am equally sure the sales have increased to kids, knick-knackers, etc. So don't be embarrassed, buy yourself a box and try it out!

There are two types of Sculpey on the market today, regular and the new "Super Sculpey." This new stuff is harder than the regular when it is baked, but it is also more brittle and

does not take carving as readily. I find the Super Sculpey good for building the skeletal structure of smaller figures that do not need a wire armature.

My approach to miniature figures varies from piece to piece. Most often ideas come from playing with the clay. By just rolling up a ball of clay and squeezing it a few times, perhaps poking it with a tool here and there, and just looking at it, I can see what it could be if I just put a little more clay here, or perhaps pulled some away there. (Everyone can "see" faces in clouds, or in the designs of tiles. This, basically is all there is to sketching in clay).

What, I suppose, would be considered THE HARD PART in sculpture, would be "technique." Technique, put simply, is getting your clay to go where you want it to, by any acquired manner. The techniques I will be talking about are "putting-on" modeling (as opposed to "taking away" carving) and blending. I will not argue the pro's and con's of "addition-modeling" vs. carving, other than to say that with a "pliable" such as clay, the obvious and logical approach is "addition." However, with a solid, firm material the opposite is obvious. (We shant, blend, and apply marble).



A trio of Whitten's wonders: "Ogre Warrior," "Hygolian Spy #2," and "Spice Miner."

PHOTOS: STEVE ARRINGTON



The "Trooper Droid" strikes a human pose. "90% of art is observation."

## SKETCHING SMALL HEADS IN POLYFORM

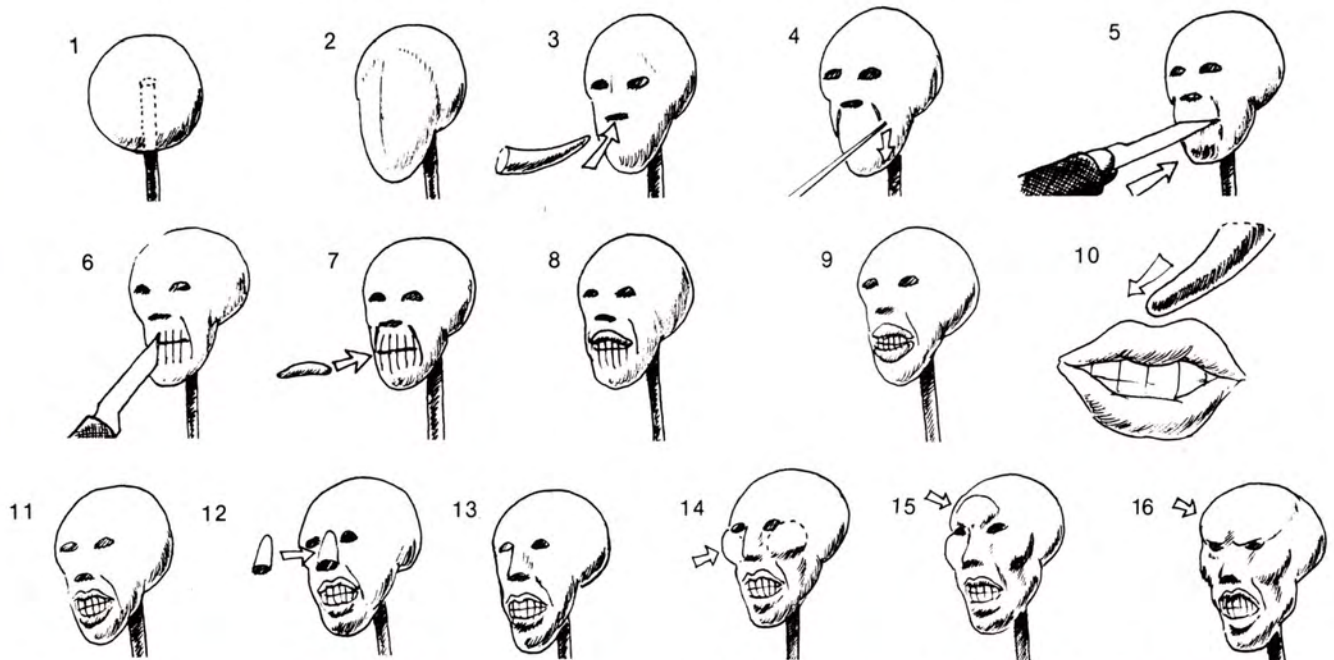

1. Roll up a ball of sculpey the size of the cranium.
2. Roll up a second ball about half that size & flatten it a bit, pinching a ridge in the center.
3. Push in indications of eyes & nose. For the nose, push up; this will bunch up the clay slightly & can make a nice pug-nose (eliminating #12 if you wish).
4. With a pointed tool, etch the muzzle with downward strokes.
5. For smaller work a paste-up blade is best, but a reg. X-acto is fine. Push slightly, instead of "slicing."
6. Verticle lines the same way.
7. Roll a small roll of sculpey tapered at each end.
8. Apply it as upper lip—blending only the top into the face.
9. Add lower lip the same way—blending only the bottom into the face.

10. One slight touch of the tool will give the groove in the center of the upper lip.
11. Often it is necessary to add material for the nose.
12. Small roll of sculpey tapered at the top—blend in with brush & paint thinner (very small amount!).
13. At this stage if ideas haven't already occured as to what you want to do to finish the head look at it closely from every angle—you should discover something soon enough.
14. Perhaps: Add small flattened balls of clay for cheeks.
15. And, or: A small "pancake" of clay, blended in, on the forehead.
16. The larger the brew, the more pithicoid & ominouse your character will be.

FIG. 1

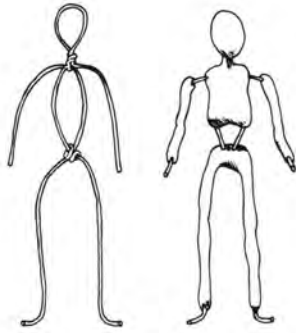

FIG. 2



FIG. 3



FIG. 4

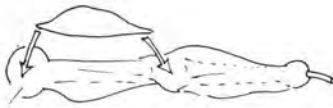

FIG. 5A

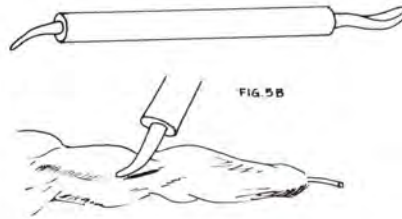

FIG. 6



## THE WILLY WHITTEN STORY

I was fascinated with "little men" (miniature soldiers) from my earliest recollections. I lived out thousands of fantasy adventures, via "transference" to a miniature character in my childhood play. A certain figure would represent "Me" in my private games—I identified with these miniatures strongly. I had "sets" of cowboys and Indians, WWII army men, Revolutionary war figures—any figure I could get my little hands on.

When I was around nine or 10 years old I saw *King Kong* for the first time on Ch. 9 movie theater—I watched every showing of it that week. The film had an incredible impact on me and figured strongly in my play from then on. Shortly thereafter toy dinosaurs became available in the stores and I would save my allowance each week to buy them. I was populating my own Skull Island (my back yard with its miniature jungles; flower beds and planters).

As I grew older I began to give up the play, but began constructing models (mostly the AMT car kits). My fascination with miniature characters never waned though, and when I discovered Sculpey in my early 20's I realized I had found the perfect medium for building my own "little men."

I began sculpting when I was about 13 years old. I got a package of Roma Pastalina that year for Christmas. I sculpted a rhinoceros. Around this



time I found an article on Ray Harryhausen and discovered the world of animation and miniature special effects. I began my own experiments, modeling in clay, casting in plaster and pulling latex skins.

So I began filming funny little 8mm table top animated films. I have always had a talent for drawing and was introduced to oil painting at a very early age. Through the years I have pursued the development of these talents and have become ac-

complished in the graphic arts, modeling and sculpture.

On the other side of the "Arts" coin I found I had a keen interest in music and a good singing voice. In the early sixties I joined a rock band as lead singer and began a career that lasted for quite a few years. I was signed to several recording contracts and released a few records. As I grew older I realized my true musical interests were more esoteric than mainstream and gradually gave up the idea of becoming a "Pop Star." At age 32 I switched directions, put music aside, as a hobby, and elevated my hobbies of sculpture and graphic arts to my new career.

I am now working in the film industry in the special effects area. The first film I worked on was released just recently, *The Howling*, for which I did the storyboards for the transformation sequences.

I also build miniature fantasy figures on commission for collectors.

Although I would love to talk about the projects I am presently working on, I'm afraid, they are "classified" (as is often the case with effects films).

Other areas of interest include poetry, synthesizer composition (muzik), science-fiction, theology, philosophy, science and futurism.

Willy Whitten  
Van Nuys, Ca.  
15 May '81

Since I am mainly covering sculpture in Polyform, I will cover my techniques of adding on and blending.

## MINIATURE FIGURES

### Ideas and Planning

Inspiration comes from something you have seen, a photo, someone else's work, a painting, or just a flash out of the ozone. . . . We all have ideas of *what* we want to do. Ideas should be no problem. I know, for myself, I have many per day. So, I think generally speaking, the ideas are there. What I want to begin with then are the two general approaches:

1. PROPER—armature, sketches and planning.
2. SKETCH—playing with the clay and "discovering" something you like and developing it.

Most often, miniature figures four inches high and less really do not need a full armature. If a figure is being made to stand, it is a good idea to use a thin gauge aluminum wire armature for the legs. An inverted "U" shape, like a bow-legged stick figure, is all you need. The reason the armature may be needed in the legs is that sculpey will soften during baking.

An armature is simply a stick figure built out of wire. Twine thread-thin wire around stick figure for grab. After you have a general pose worked out in your armature, put a thin layer of sculpey around it and bake (Just about 10 minutes at 275° is fine for small pieces). (Fig. 1).

If you are sculpting a human or a human-like figure, it is a good idea to study some anatomy. There are many good books on anatomy on the market, or you can even get good studies of surface muscles in many super hero comic books. And, of course, there is always the mirror. Also, there are a lot of us running around on this planet, look at people closely, not just for anatomy (the beach is best here), but for expressions and character. The texture of wrinkled skin, drapery, how clothes fit, the way the material forms at a bent elbow, the way loose material hangs: 90% of art is observation.

After you have your basic stick figure of sculpey over a wire armature, make skeletal points. These can be simple balls of clay at the primary joints. Or more time can be spent in sculpting an actual bone structure of various finishes. At any rate this is a good stage to put the rib mass onto the figure. Bake again for 5 to 10 minutes for small pieces. (Fig. 2).

Obviously your model will be very hot when you first pull it from your oven. If you are anxious to get back to work on it you can hold it under cold tap water to cool it down (to no adverse affect on the sculpey).

Now that you have a skeleton, the next step is to apply the muscles. The exactness of the muscle placement depends on several things and will vary from piece to piece. It depends, of course, on one's skill to a large degree, on taste, whether the figure will be draped or not, etc. If a figure is to be wearing heavy garments it is a waste of time to bother with more than mass placement of musculature. Light clothing should have a fairly accurate underwork of musculature and, of course, nude portions should be modeled as accurately as possible.

I usually begin application of the muscles in the abdomen and waist area and work up to the neck and shoulders. The reason for this is, once you have your torso "massed in" you have a better idea of the "bulk" of the overall figure, and it is quite easy to have the arms of a stick figure resting closer to the body than you had planned. Minor adjustments in the posing of the limbs can be made at this time when the sculpey is fairly resilient in the skeletal thickness. (Fig. 3).

If you have experience working with pastalina, let me point out some differences in the "feel" of sculpey. It does not blend quite as well as Roma or other high-grade pastalinas. Therefore, the additions should be made in close shape to the shape you want on

the model and "pressed" on as opposed to the pastalina technique of applying a basic glob and "smear-blending." This approach can be done using paint thinner as a blending agent (I will cover this later). But, I think it is best to learn the properties of the material itself.

The muscles should be applied in strands; try to estimate the proper sized strand and lay it onto the form in the same manner real muscles are connected to the skeleton. (FIG. 4).

This is the most convenient all-around tool for sculpting miniature figures in Polyform. (FIG. 5A).

The bottom edge of the curved, pointed end is best for pressing the muscle strands together. (FIG. 5B). It is a good practice to sculpt from the center of your model outward to the extremities.

A small pointed "detail" brush (or eye liner brush) is good for blending and brushing out any tool marks. Paint thinner will help soften the surface clay. But, use it sparingly, dab your brush on a paper towel before brushing your model. (FIG. 6).

Experiment with brushing, as there are many possibilities. Many textures can be achieved this way as well as minute sculpting, such as veins and creases.

I generally work a portion of a model,

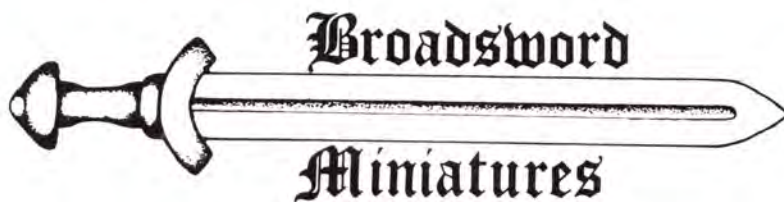

CHARACTERS OF QUALITY -

NOT JUST FIGURES



CALL OR WRITE

2442 "C" STONE MOUNTAIN -LITHONIA ROAD

LITHONIA, GEORGIA 30058

404-482-8891

an arm at a time or the left side of a figure and then bake it. It is convenient, having the part you have already worked solid and unmarrable. I will usually bake a figure up to ten times before it is complete.

### The Head & Face

Very often it is the head & face of a character that I come up with first because of my habit of sketching in clay. I have boxes full of various scale heads awaiting bodies. But on commission pieces, or figures that I am doing from photos or drawings, I usually go the whole proper route of building an armature, exact posing, etc. In this case the face is usually the last part to be modeled. (See typical steps in sketching small heads in sculpey.)

Once the anatomical stage is complete, it is time to add any garments and equipment. There are as many approaches to this stage as there are figures to be made. Again; study drapery carefully, the fold and fall of material must look natural or the appearance of the whole figure will suffer. Although I generally sculpt the clothing in sculpey other methods can work quite well. One technique is to cut patterns from facial tissue. Dip these in a solution of water and white glue (about half & half). After you have

dipped the tissue, lay it on a mirror or sheet of glass and lightly dab it with a paper towel to draw out the excess liquid. Carefully lift it and drape it onto the figure. A toothpick is a great tool for working the tissue into folds and creases. After the garments are positioned you can place the piece back into the oven (very low heat) to accelerate the drying time. Don't be concerned if tight creases and tips of the tissue turn yellow or brown, you're going to paint the model anyway.

Another method that I use for very tight fitting clothing is painting minute folds and creases with acrylic paint. Although this can be tricky and takes a bit of practice, the results can be quite satisfying. The acrylic paint, straight from the tube has enough body to hold quite a bit of shape. Tiny buttons and bumps can be added this way very quickly. (The knuckles on "Trooper Droid" are spots of acrylic and much of the "tubing" detailing on the "Spice Miner's" costume was done this way).

Combining mediums can be beneficial and a lot of fun. I usually fashion weapons out of metal or styrene. "Trooper Droid's" blaster is made from a paperclip partially covered with sculpey and detailed with acrylics. The pistol (which can be pulled from the holster) on "Mezulisian Bandit"

was fashioned out of styrene, as was his knife. The lamp on the side of "Spice Miner" has a headlight lense from a 1/25th scale model car kit.

I use acrylic paints (artists type—in tubes) almost exclusively for painting my sculpey figures. For skin tones and cloth, a matte finish can usually be achieved by applying the paint in washes, rather than a creamy blend (like oil paint). For more matte in your finish you can also brush powdered pastel lightly over your finished acrylic.

Both "Trooper Droid" and "Starship Trooper" were detailed with rub type (transfer lettering) after painting with acrylics. The 3-M Company has kits available for making your own transfer lettering or any other rub transfer design. It is done with photo solutions and a dark room technique. So any negatives you have or can create can be used to make these transfers. With proper developing these transfer sheets work great and have a remarkable shelf life.

Getting small is a state of mind. I find that when I am working on a miniature figure, my best work occurs when I can envision myself as being in the same scale as my model. It can be a magical experience to glance up from the piece I'm working on and see the world as a giant place. ▲

# DRAGONS BY DRAGONTOOTH



**WRITE FOR A FREE LISTING TO: TOM LOBACK GENERAL ARTWORK  
152 WEST 26th ST, #36 NYC, NY 10001**

# MODEL GIRL

## or Making Lovely Ladies

By MARTIN J. BOWER



PHOTOS, MARTIN J. BOWER

**I**t was not really that difficult to find the inspiration necessary to start work on the model to which this article is dedicated. Although I'm not really quite sure why I ever thought of making a model of a girl. I suppose my fascination for all types of miniatures and a natural interest in women led to this amalgamation of ideas. Whatever the reason, I now find something rather cute about having a 2 foot high lady standing on my TV set! Indeed it was probably worth making her just to see the reaction I get from people when they first set eyes on her.

Anyway, the following article is intended to give you some idea how I went about making the model and, I hope, give you a few helpful tips if you want to follow suit. The photos on these pages, I hope, show something of how it was done, and indeed what the final model can look like if photographed carefully.

### Making your original model

I found the best substance to build



**Above: Ladies' man Martin Bower and his handiwork.**

the master model in was plasticine modeling clay. I got an excellent finish by smoothing it out with petroleum

jelly (vaseline) and/or lighter fuel. Both mix with the plasticine and help to blend out unwanted marks. I found this substance easy to work, it stayed pliable and did not tend to dry out as many ordinary water based clays do. This made it less messy because there is no need to keep wetting the material to keep it workable. So having said that where to begin?

Well first of all decide upon the size you want the model to be. I chose 1/3 full size, giving me a completed model just under 2 feet high. There were several reasons for this choice. In order to achieve maximum realism, which was what I wanted, you need to get a certain amount of detail into the model. Below this size it gets rather difficult. In particular the hair needs to look good and since I used real human hair it is rather difficult to scale down. The same also applies with material for clothes, as even a really fine cloth will look out of proportion on a model. Whatever size you decide upon, the next step is to draw out a rough sketch, or several rough sketches to get the

proportions of the overall model correct. Don't worry if you're not that good at drawing; reference to a few pictures is invaluable. I must admit I found the gatefold of a girlie magazine helpful—more often than not the picture is printed almost exactly 2 feet high.

Next, it is down to making a wire frame to build the plasticine up on. Soft aluminum wire is readily available to sculptors, and is the best. The 3/16 inch square variety I found fine. Fix the wire "legs" into a baseboard about 9 inches x 5 inches securely. I glued mine in because there is nothing worse than the model toppling over and getting damaged when it is nearly complete. Make up a basic "matchstick" man shape ending at the wrists and minus the head. The hands and head are made separately. Now comes the hard part. There is no way I can tell anyone how to sculpt a figure without actually showing them, so I guess it is a case of practicing a little, or a lot, before attempting the model proper. Patience is what is needed more than anything else, if you don't have much you may as well give up now. Don't try to get it to a fine finish immediately, just build up a basic body shape to start with. One of the best helps is reference. Any pictures are a help particularly those in books on life drawing. I also found Frank Frazetta's and Boris Valejo's paintings and drawings of great help. The girls painted by both men, with their exaggerated muscles and features and sensual feel are invaluable when building a model of this type. How you make the girl look (slender, plump or whatever) is of course up to your own taste. One thing to remember though on this plasticine model is to keep the arms straight, in line with the body and at about 15° to it. If you bend the elbows at this stage it will cause the model to catch in the mold. I found bends in the arms best to do by cutting and filing the final glass

fibre model carefully.

As for tools for working the clay I made my own plastic sprue and wood. I found the shop-bought ones rather poor. I may have just been unlucky. You can use those shown as a guide if you do want to make your own. Now it is just a case of working on the model until you are satisfied with the results.

Reference is vital in making the head: any pictures of girls you like though are fine. If you can get them the size of the actual model it is a great help. I built the head for my model up on the ball handle of a screwdriver. The handle being about an inch and a half in diameter was an ideal base. The steel stem becomes the handle while you work on the head. Cover the handle with plasticine in a small layer and decide the position of the eyes. Now push two steel ball bearings (5/16 inch for a 1/3rd scale figure) into the eye sockets. These become the actual eye ball, as without these it is very hard to retain a round eye shape. Now you can go ahead building up a face. On my model I made the ears and molded them separately. However as it turned out, you don't see them anyway! Remember to leave the neck a little overlong as it can be cut on the glass fibre final model to the right length. I also found with the head that I needed to brush on the lighter fuel with a fine paint brush to get a good finish as my fingers are just too big.

Now for the hands. Make two wire frames leaving the wrists overlong so that you have something to hold. This time, though, use a much finer wire than that for the body. Once again patience is needed until a reasonably realistic hand is modeled.

So after all this you should hopefully end up with a complete body, legs and arms as one model, and a head and hands separately.

#### To Make the Mold

Because I used plasticine as my

medium, the choice of what to make a mold from is very limited. It really needs to be in rubber, preferably of the 'cold cure' variety. A rubber which is heated to become molten and then allowed to set as it cools will also melt the plasticine when poured over your carefully prepared original. This cold cure rubber is the only real expense incurred in the model, as quite a bit is needed (8 one pound cans).

It may be that some people will say why not make the original in clay and fire it to get a solid model, hence disposing with molds altogether. Well yes you can do that if you wish, but I found after several attempts that the final model was nowhere near as good in finish as with the plasticine method. With plasticine the final model can be rubbed down, painted, rubbed down and painted and so on to obtain a really smooth, fine finish; also a more realistic eye can be made if it is fitted after painting, something not possible with a solid head.

The next step is to build an open box in wood just big enough to surround the model: four sides and a bottom screwed on for reasons that will become apparent. By laying the figure down, the base becomes the bottom side of the box.

The next stage is to build up in plasticine to a level half way up the model, effectively covering the back half of the model. This is so the top half of the mold can be poured first. The "fill in" plasticine should only touch the model at the center line so as little damage as possible is done to it. Any dents caused can always be removed later before pouring the bottom half. If you attempt to pour the bottom half of the mold first, i.e. pouring straight into the box until the level of rubber reaches half way round the figure, it is quicker, but all the air bubbles in the rubber rise up and settle against the bottom of the model and spoil the finish in the mold.

When the top half is dry (it takes anywhere from 2 hours to 24 hours depending on the make of rubber you use) turn the box over with the model inside, laying it face down on a flat surface. Unscrew the bottom of the box, remove the fill-in plasticine and repair any dents that may have occurred. You can repeat the process and pour the bottom half of the mold (now of course the top) directly onto the model. I found no need to use any release agents but some rubbers do tend to stick to each other so experiment first.

When the second half is dry, dismantle the box, peel the two rubber molds apart and dispose of the plasticine model. You have the molds.

The same techniques should now be followed for the hands and head and you should eventually end up with:



**The head was built on the handle of a screwdriver. Fine wire was used for the hands.**



**Bower's homemade tools**



**Left: Patience is required when handling hands.**



**Right: The finished product.**

- 2 body half molds
- 4 hand half molds
- 2 head half molds

**To Make the Glass Fibre Model**

The next step is to make your glass fibre model. There are many books and pamphlets explaining the in's and out's of fibre glassing. So I will assume that you can refer to one of these if you haven't done it before.

After applying the release wax to all the molds proceed with the glass fibre until you have a thin layer in the head and body molds. The hands however should be molded in Filler Paste (ISOPON) or some similar substance only, and are therefore solid. Trim off the glass fibre to the edge of the mold before it is completely dry. Once thoroughly dry remove from the molds all the pieces, clean with soap and water and you are ready to stick

the model together. Filler paste and resin are both good glues. Once stuck, you can fill in the joints and with filler paste, rub down until you are satisfied with the result and then primer the whole model twice, rubbing down between coats so that a really smooth finish is obtained; particular care should be taken with the face and the hands. Once the primer is dry, cut a small slice off the back of the head so that you can put the eyes in from behind. Drill the eye area out and file it carefully so that the ball bearings you used in the plasticine model fit closely behind the eyelids. The better these fit, the better they look. Later, as will be seen, these eventually become the eyes of the model.

The model can now be painted. I used matt oil paint ("HUMBROL") sprayed with an airbrush. A small spray gun can be used, or it can be

brushed. The airbrush is however very useful for shading the model and adding complexion to the face.

When the paint is dry the eyes can be fitted from behind, through the hole cut at the back of the head. I made the eyes, by painting the ball bearings mentioned earlier and giving them two coats of glaze. Afterwards stick the back of the head back on. For eye-lashes I cut down human false ones but very fine ones, as thick heavy lashes look completely out of scale at this size. The eyebrows were just painted on.

Finally, the hair. I was lucky in finding some very fine human hair but if you can't get this, mohair or nylon is OK. Glue it firstly into small bunches about 1/8 inch across leaving it long. Then when you have a number of these start sticking them onto the scalp area, starting at the bottom, so that each layer of hair covers the glue on the layer below it. Work up finally to the parting, where great care must be taken, as excess glue will spoil the whole job. Now give her a haircut and you should have a completed model, albeit rather naked!

Maybe you prefer her that way, however the clothes on my model were made from fine nylon material and all I will say about them is that I made and sewed them directly onto the model. That way they fitted really well.

I decided after completing my model to go one stage further and start equipping her with various futuristic weapons and devices. Since I decided that the girl was perhaps the pilot of some futuristic plane or spacecraft I gave her a small oxygen pack, made from a plastic disposable syringe cover decorated with tape. The pipes and hoses I made from very fine coiled springs but plastic tubing would do equally well. The ray gun however was built from scratch and was a whole model in itself as was the small direction finder she is holding. Finally her sunglasses were made from a section cut out of a blue transparent plastic container. I admit I was lucky that it was the right size! After all this was done I took the photos shown here. One photo was subsequently sold and used to publicize an intended puppet series. "Jungle Girl" was my second model made from the same molds. After molding I cut the fibre glass model and altered her pose. The head was a new one made from scratch like the first.

Initially the second girl was used in a jungle scene setting clad only in a scanty bikini and equipped with sensors and only a dagger for protection. Later however the same figure was adapted as you can see for a very different use. With new clothes she appeared for a photo on my personalized Christmas card! △

# SNOW WALKER

A Review of MPC's Latest Star Wars Kit

By ANDREW P. YANCHUS

They have been called by many names: Imperial Walker, All Terrain Armored Transport (AT-AT), Snow Walker, and even "those big elephant things"! But, however different people refer to them, there is general agreement that these mechanical monsters were one of the highlights of a motion picture that was a solid two hours of high adventure, fantastic imagination, and breathtaking action—*The Empire Strikes Back*. *Empire* not only continued the *Star Wars* saga on film, it also created new worlds full of creatures, characters, and vehicles to be merchandised and fill the book shelves, toy stores, and hobby shops.

MPC, the hobby kit division of Fundimentions, has just released the Imperial Snow Walker in plastic kit form. It is the tenth in their series of *Star Wars* items. Earlier *Star Wars* kits have received mixed reactions. Most have been good, strong sellers; one in particular, the large, "breathing" Darth

Vader head, was a sales dud, and was quickly discontinued. On the whole, the various kits built up into realistic, accurately detailed models, but there have been a few cases where it seemed that MPC designers didn't do their homework, or that management got tight with tooling dollars. How does the Snow Walker fit into all of this? Well, it is clearly one of the best kits in the series. Though it's not entirely without faults, I doubt that anyone will be totally disappointed with this kit.

## The Breakdown

The Snow Walker kit is made up of 80 molded plastic parts and a rubber band. The rubber band connects the head and body through the neck, and allows the head to be positioned in a great number of attitudes. Other moving parts include the legs, naturally. However, MPC has cut some corners and simplified assembly here by making only half of the legs fully jointed.

While the front legs bend at the knees and ankles, the rear legs are molded solid, but all four legs can be moved at the hips. Anyone wanting articulation in all four legs will have to obtain two kits and use two sets of front legs, as I did on my model.

The kit also includes two Rebel Snowspeeders and two Laser Turrets. Although comprised of only two pieces each, the Snowspeeders and the Laser Turrets are too small in comparison to the Walker. It was this obvious disparity in sizes that got me started checking the scales of all the pieces.

## Scale

Calculating the scale and checking the accuracy of the model were simultaneous operations. A number of publications were used for reference: *The Art of the Empire Strikes Back*, *The Empire Strikes Back Sketchbook*, *The Empire Strikes Back Storybook*, the June 1980 issue of *American Cinematographer*, and, finally, *Cinefex*



PHOTOS: PHILIP O. STEARNS

**The Snow Walker with the foot as it appears in the kit on the left and as modified.**



number two and number three.

In order to work out the scale of the 8 $\frac{3}{8}$  inches tall model, the first problem was to determine the "actual" height of the Walker. Most of the illustration in *Art of the Empire* and the *Sketchbook* didn't help because the drawings were of early design concepts that did not depict the final configuration. It is obvious that George Lucas and company had many different ideas on the size of the Walkers, because these preliminary sketches, complete with humans for scale, put the Walkers anywhere from 35 to 83 feet in height! Some sources quoted 40 feet as the critical dimension, while 50 feet was oft mentioned in others. Tom West, MPC's Product Manager, said that the 50 foot height was correct.

I was anxious to accept the 50 foot dimension because it would make the model exactly 1/72 scale, which is one of the most recognized standard scales for model making. But, I wasn't totally convinced. The head of the model Walker appeared too small to house a 1/72 scale crew of three, so I continued to check out other size relationships.

One of my reference books contained a good shot of Luke Skywalker's Snowspeeder being crushed by a Walker foot. From this, it was evident that the Speeders in the kit were too small, and it would be necessary to determine the "actual" size of the Speeders. I found that the published sketches and plans for the Snowspeeders were more consistent to the final design than the Walker plans were, but they still contradicted themselves. I could only find one drawing that contained a usable dimension—a wingspan of 12 feet 6 inches (*Art of the Empire*, page 49; a magnifying glass helps). This dimension made the Speeders included with the Walker 1/114 scale. MPC's separate, larger Snowspeeder would then be 1/21 scale, but this couldn't be correct, for the crew figures would have to be almost 3 $\frac{1}{2}$  inches tall, far too large to fit. Based on other design drawings and human proportions, MPC's larger kit must be about 1/25 scale, which put the real Speeder wingspan at 14 feet 10 inches.

Even with a 2 foot 4 inch discrepancy in actual size (3/8 inch in 1/72), cardboard cutouts of the Speeder compared to the plastic foot and the photo of the trampled Speeder added to the case for 1/72 scale.

The last bit of confirming evidence clicked into place when I discovered that the one Walker design drawing that came closest to the final version was the one with dimensions that brought the model closest to 1/72 scale. This is the drawing labeled "Engine Detail" (*Sketchbook* page 37, and *Art of the Empire* page 52).

If this seems like a lot of preliminary

work, believe me, it was! But, it was all necessary in order to determine what could and could not be included in a scene with the Walker. My decision to include Luke Skywalker was made entirely on the basis that the model was 1/72 scale (I had plenty of figures in this scale), and that the included accessory items were too small. Some people may not agree with my conclusions (I still doubt the interior space of the head myself), but more checks pointed to 1/72 scale than anything else. It is a possibility that the film people cheated in depicting the Walker, and used different sizes and proportions of various components to create the best effect for each scene. If such was the case, then no specific scale is correct, and the creation of an "impression of correct scale" would be the most anyone could hope for.

### Accuracy

While it might be difficult to pinpoint scale on a model of this type, it's easy to check for accuracy of detail. All one has to do is put the model parts up against photos from the movie. When I looked over the MPC kit parts, I was pleasantly surprised to find that most of the shapes and details matched the studio models in the photos. I did not find any detail in the wrong place, nor was there faked detail that didn't belong. What I did find was a lack of detail in certain areas, notably around the feet. But, it seemed that in most of these cases, the detail was missing because of molding limitations rather than sloppiness or cheapness on MPC's part. For example, the curved bar that creates the ankle joint has recesses on both sides, but there should also be another recess along the top. There should be a series of panel lines around the base of the feet, and some protruding detail above the toes. The bottom of the feet are not detailed at all; what appears on the model foot plates are various molding necessities.

There are a few other bits missing, mostly around the flat plates that connect the engines to the rest of the legs. Nit-pickers will note that the small hatches on the sides of the front and rear segments of the body should be slightly recessed, but are flush on the kit. The model's biggest fault in proportions seems to be with the legs, which are too close together in width.

### Construction

I won't dwell on part fit because my model was built from early test samples kindly supplied by MPC. There was some slight misalignment on a few of the leg halves, and the various leg joints were very loose. These, and a few other minor fit problems, should be rectified by the time the kit is in production. The area that needed

the most putty and sanding was the joint between the top and sides of the body, where the body increases in height. Putty was also needed where the ankle bars attach to the feet.

Basic construction was pretty straight forward, and the various sub-assemblies—head, body, chassis/engines, and legs—went together with little effort.

Although my model was solidly glued into one position, I used four articulated legs from two kits to get a better feeling of action. (there is absolutely no problem in using all front legs; except for the joints, the front and rear legs are identical.) Even so, I had to modify the knee joints on some of the legs. As supplied in the kit, knee joint movement is limited by clearance slots molded into the bottom half of the joint. To get a leg to bend back more, I simply lengthened the slot on the back side of the leg. This, unfortunately, also resulted in a gap in the front side of the leg that had to be filled once the position of the leg was finalized.

To duplicate the missing panel lines around the feet, I first sanded off the few raised lines that were there. I then penciled in guide lines, and scribed the lines using a knife and flexible metal straight edge. I used some tiny plastic rings (fittings from a ship kit) to replace the missing detail above the toes. The actual detail should be oval, not round, but the rings were the closest thing I could find to the correct shape, and, to me, they were better than nothing at all.

The only other detail I added to the Walker was a piece of clear red plastic (model car taillight) to the window in front of the head.

### Painting

There is one aspect of this new kit that made painting a little different than usual. All of the door and panel lines are represented as raised lines. These lines are crisp and clean, and are neither too light, nor too heavy. But, for proper appearance, they had to be darker than the body of the Walker, and painting them seemed to be a tricky situation. I couldn't see picking them out with a fine brush after everything else was painted. Then I remembered a technique I had dreamt up several years ago for painting raised grain on plastic wood. I never had the opportunity to try the idea, but the raised lines on the Walker posed the same type of problem, and became the perfect test.

After the various sub-assemblies were glued, puttied, and sanded, I primed the entire model with *semi-gloss* black enamel. After the primer was dry, I painted the model with various shades of Pactra *flat* gray enamel, and carried out weathering with thin washes of dark gray and

black. I also painted in rust streaks in several locations. Next came the twist. With cotton tipped swabs, I rubbed the soft, flat gray paint off the raised panel lines. The tougher, semi-gloss black paint resisted the rubbing, and popped through where the flat paint was worn away! This technique was also used to accentuate edges and other raised detail. Hard to get at lines were lightly scrapped with the tip of a sharp knife. The rubbing gave a shine to the flat paint, so I had to top the model with a coat of clear flat to bring everything to the same degree of finish. I'm sure that this flat-over-gloss-rubbing method can be used with various color combinations to accent or weather other types of models.

### The Snow Scene

To add some interest to the final model, I decided to set the Walker in "snow," and have a miniature Luke Skywalker running along side of it.

Luke was no problem. He was fabricated from a couple of Preiser and ESCI World War II German figures, and detailed with small scraps of plastic. *The Empire Strikes Back Storybook* contained an excellent photo of Luke clinging to the bottom of the Walker, and I used this photo as a guide in making the magnetic grapple Luke uses to get up under the Walker. This photo shows Luke's boots and gloves as light gray, but I painted them black for greater contrast against the snow.

It was the snow that gave me the most problems. I had never modeled snow before, so I checked every "How To . . ." book I had to see what the experts had to say. None of them said very much on the subject, and they all recommended different approaches to the solution. I tried a few ideas involving baking soda, but wasn't happy with the results. I finally settled for pouring plain Plaster of Paris on the base, and sticking the model into it. Of course, even this involved some trial and error, and a few mixes until I could eliminate all the air bubbles, get the right consistency, and not have the plaster set hard before I got all the detail in. If you are doing snow for the first time, be prepared to waste a good deal of time and materials on experimentation.

The creation of the snow scene required one additional piece of modeling. In a scene, a Walker would have to leave at least one footprint in the snow, no matter how small that modeled patch of snow was. Details of the bottom of the feet were hard to come by, but I found one fairly clear shot in the June 1980 *American Cinematographer* (page 566). Following this photo, I scratch built a foot bottom that was detailed enough to make a decent impression in the wet plaster.

### Conclusions

MPC's Snow Walker is a very good, trouble-free model that is fun to build. The kit can serve as the basis of many different diorama ideas—a group of Walkers descending on the Rebel troops, one crushing Luke's Snowspeeder, one falling over, or others being attacked by Snowspeeders. Some of these suggestions would require scratch built Snowspeeders in the proper scale, but that shouldn't be too difficult a task for the more ambitious builders. Home movie makers will have little trouble in modifying the kit for use in their own animated films. And, if you have to buy two kits to get

one set of fully articulated legs, don't worry; the extra parts from the second kit will find their way into other model building projects.

*The Star Wars Snow Walkers* were inspired by some walking machine concepts created by Syd Mead for US Steel. Mead's illustration for a "Four-Legged, Gyro-Balanced, Walking Cargo Vehicle," and his description of how such a machine would operate, appear in *Sentinel*, a collection of Mead's fantastic illustrations and published by Dragon's Dream (1979). The book is worth checking out. At the very least, you will see the pattern in a long trail of Walker footprints. ▲



## OTHERS MAKE CLAIMS...SUPERIOR DELIVERS

It is easy to make claims, that's why we at Superior Models ask you to compare. Cast in a unique alloy to insure fidelity of detail, you don't have

to be a wizard to see that these highly detailed, accurately scaled 25mm figures will more than satisfy the fantasy gamer and connoisseur alike.



DISTRIBUTED BY

**ALNAVCO DISTRIBUTORS | COULTER-BENNETT Ltd.**

804-442-2323

213-980-1887

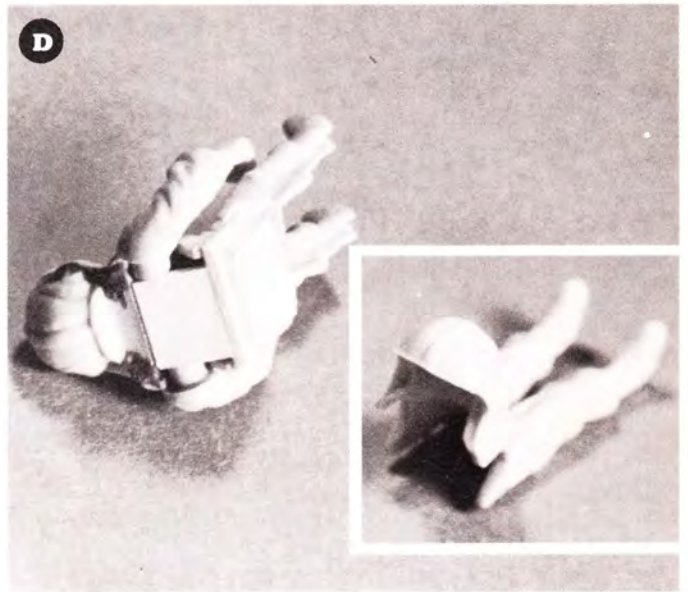
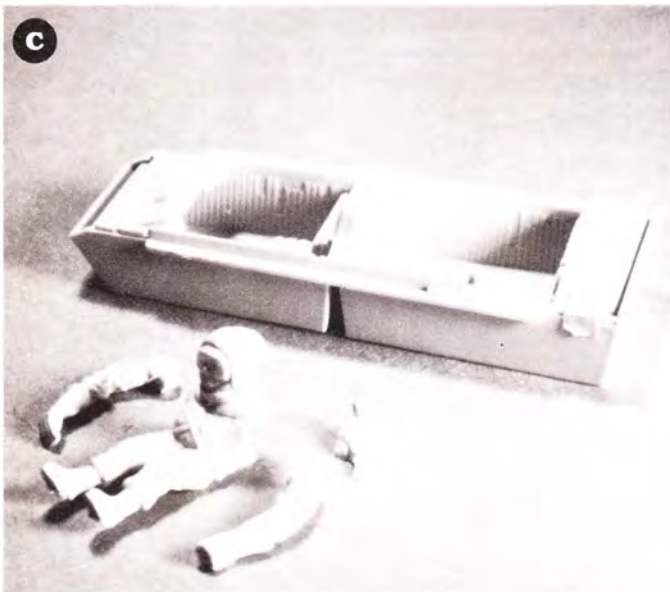
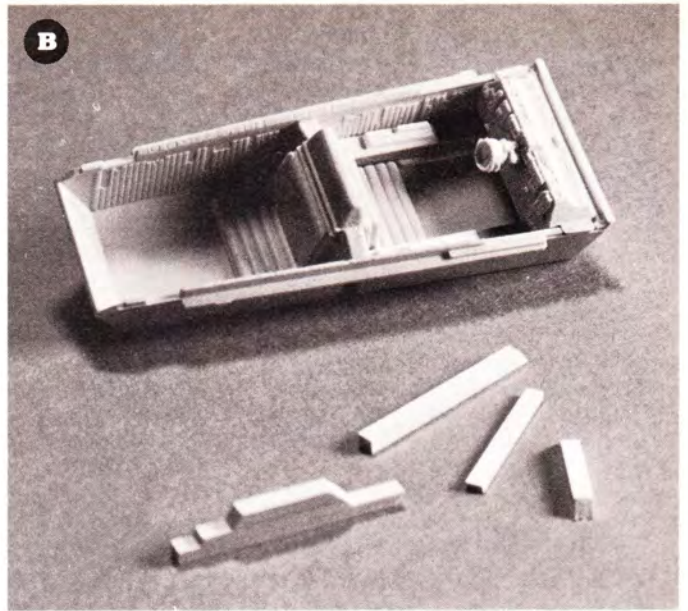

**A:** A 3/16 inch section was cut out of the arm. Compare the stock arm to the shortened arm in the background. **B:** Extra detail was added to the cockpit on all sides. **C:** The stock cockpit and pilot figure. **D:** The modified pilot (left) and the stock pilot. **E:** The completed pilot figure. **F:** Center section with transparent windows cut out for clearance of raised pilot's head.

PHOTOS: JEFF POLLIZOTTO



# LUKE SKYWALKER'S SNOWSPEEDER

Super-detailing the MPC kit

By JEFF POLLIZZOTTO

**T**he latest addition to the ever popular line of *Star Wars* model kits by MPC is the Snowspeeder—seen in action on the planet Hoth in *The Empire Strikes Back*.

The kit contains approximately 75 detailed pieces and comes molded in off-white. The snowspeeder kit contains extras that have been lacking in some recent film models. A detailed cockpit with pilot and tailgunner figures is included along with a working canopy and operating control surfaces.

The main body consists of two major parts (top and bottom) with the kit parts assembled to the surfaces. The cockpit is a separate unit, built up and cemented to the top half of the body from below. Though already well detailed, I planned to add extra detail to the cockpit area and add "battle damage" and weathering to the

---

**Completed Snowspeeder kit mounted on its wood base. Note plaster "snow" detail.**

model's surfaces.

Test fitting the parts was the first step in construction. I like to familiarize myself with the parts in a kit and read through the plans to check on their placement before any cementing is started. It's a good idea to read the plans before you begin any model.

After I'm familiar with the kit parts and their placement, I began to cut the pieces off the runners. Don't twist the parts off, cut them off with an X-acto knife or (a method I find that works better) saw them off with a razor saw.

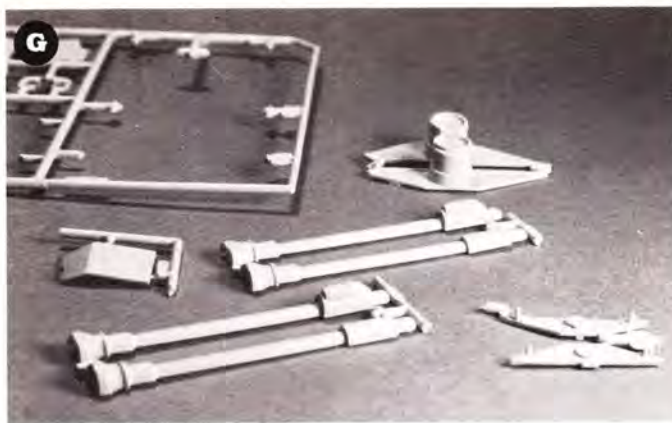

The saw makes it an easy job and you can slice off the extra piece of runner with an X-acto. Trimming the parts in this fashion makes for a cleaner part and a better built scale model. Any "flash" was cleaned off the parts at this point in construction. Even the best kits have a certain amount of "flash" to them.

Actual construction of the kit began with the cockpit. I planned to add extra detail throughout the kit and I found two books that proved to be invaluable. *The Art of the Empire Strikes Back* and the June 1980 issue of *American Cinematographer* had excellent research material on cockpit detail, battle damage areas and weathering schemes that I incorporated into the model.

To give the cockpit a more three dimensional look, I build additional control surfaces on both sides of the pilot and tail-gunner sections using 1/8 inch x 1/8 inch and 1/8 inch x 1/16 inch Plastruct and Evergreen strip stock. A 1/16 inch sheet provided a floorboard "kickplate" in the tail-gunners area. Various small parts from my "junk parts" box were used to build up surface detail on the control surfaces and strips of styrene were added to simulate switches and controls. The cockpit was then put aside for painting.

The pilot and tail-gunner figures supplied are the least detailed pieces in the kit. The biggest problem was the size of the figures arm length. I test fit the figures together and set them up in

the cockpit. Using the drawings found in the *Art Of The ESB* and my own body as a guide, I found that the arms should only go as far as the knee when sitting. The arms on the figures went almost to the ends of the legs. By cutting out a 3/16 inch section from each arm (right behind the gloved hand) and re-cementing the hand to the arm the figures looked more "normal." This also made them fit into the cockpit better. Another problem I found with the figures is that they don't sit high enough in the seats.

By adding a piece of 3/16 inch sheet plastic to the "seat" of each figure, they will sit high enough in the seats to look "normal." By raising up the figures this way the open back will show so they had to be filled in. I filled in the back of each figure with a piece of sheet plastic and built up the "back" with Green Stuff putty. The mismatched seam lines on the pilots helmet that ran into the shoulder area was filed and filled with putty. The "rib" running down the center of each helmet wasn't high or square enough so I filed the entire top of each pilot's helmet smooth, and cemented a new "rib" down the center using a 1/32 inch strip of Evergreen plastic. With the pilot and tail-gunner figures properly detailed, they were given a coat of primer and when dry, were painted flat orange. The boots and gloves were painted flat black and extra belt or strap detail was added to the figures. The faces were painted next and, when dry, the helmet and suit details

were added on. With a good amount of extra detailing (as well as time) the figures turned out to be a good representation of the actual pilot figures.

Now that the figures were finished, I wanted to give them a place to occupy. The assembled cockpit was sprayed (in three pieces) using Duro brand automotive primer. Sections of brass "piping" were added to the side sections to simulate electrical conduit. The instrument panels were detailed with paint and the target screen decal was applied to the forward control display in the pilots cockpit. Note: the decal that says "gunners target screen" is actually the pilots screen decal. There is no decal supplied for the tail-gunners' screen so I drew a screen of my own design on a piece of thick paper and cemented it into the hole on the end of the tail-gunners' targeting device. The control panels were then cemented to the cockpit and the figures put in their positions.

With the cockpit finished (I spent the most time on the cockpit and figures) I began to assemble the main "body." Test fitting the canopy to the upper half was the first step. It was a little too large to close accurately so to get a proper fit I had to do some filing along the back edge. The inside surfaces of the open "windows" were also filed smooth because they had a good amount of "flash" on them (due to the molding seams). All edges on the "body" parts were sanded and I fitted the major parts to check for accuracy.

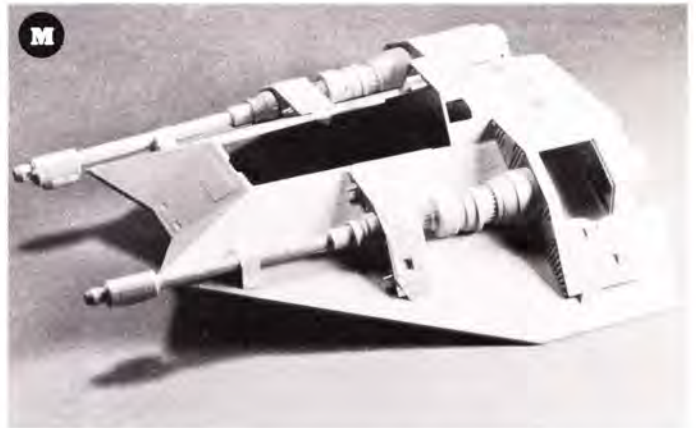
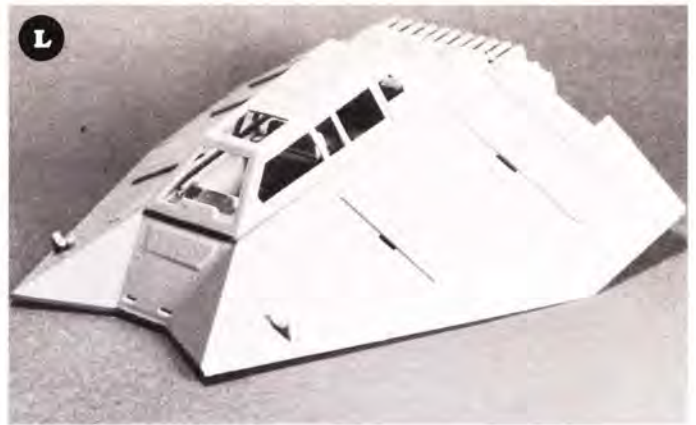

**G:** Parts cut from runners, ready for trimming. **H:** Detail of kit parts in the process of being painted. **I:** Sideview of cockpit showing the relationship between pilot, modified (left) and stock. **J:** Detail of battle damage showing a typical laser hit cut into leading edge of model. **K:** Gun parts with "keyways" filled in with Green Stuff. **L:** Bottom half of body with new mounting support shown. **M:** Major sections of the model taped together to check fit of parts.

Now that the pilots were modified to sit higher in the cockpit, the thickness of the clear window prevented the canopy from closing properly. The middle of the window was cut out with a razor saw, and the edges were filed smooth. Thin clear styrene was then cemented to the underside of the canopy (below the open window) after painting.

I cemented the gun halves together next with liquid cement and I used a small amount on the seams (from the outside) to melt the plastic slightly and "weld" the halves together. When dry, it was just a matter of filing and sanding (with 400 Wet-n-Dry) to smooth out the seams. I also drilled a hole in each gun end to simulate nozzles. The assembly of the large and small triangular shaped pieces that attach to the guns came next. The smaller (forward) units were cemented on the surface but the larger ones were left off for now. Because of the rounded ends of the larger units, it would be better to spray them off the model to get better paint coverage. The guns were painted as separate units for the same reason. The same air scoop was next cemented to the upper "body" (on the right side) but I left off the front piece. Research showed that the scoop was open in front so the part was left off.

At this point in assembly, I decided to add some "laser hits" to the ship. Researching through my books, I found out the location of typical "hits." With an X-acto knife (set up with a sharp #11 blade) I nicked some areas along the edges of the "body"

and also along the leading edge of the gun support sections. Remember, don't dig too deeply, you won't need much to make a realistic "hit." The battle damaged areas will later be weathered after painting the model.

With all the extra work that I was putting into the model, I wanted to display it on a stand that would enhance it. The plastic stand was discarded in favor of a 5½ inches x 9 inches wood base. I covered over the two original mounting holes in the body with strips of 3/32 inch strip styrene and a new mounting hole was drilled 1/8 inch behind the forward strip. A 1/8 inch brass tube was used for the actual support. A hole was drilled in the base and the tube was epoxied in place. The upper surface of the base was then covered with Hydrocal molding plaster (the type that doesn't shrink) to simulate Hoth's icy surface. The socket in the base of the model was made from a 5/32 inch brass tube that was epoxied inside the lower half of the body. Strips of 1/8 inch styrene were epoxied at right angles to the brass support to help steady it. The brass rod was then painted flat black.

The center section that attaches to the lower body half will be left off for spraying and assembled after painting. The parts were then set aside for painting.

Using Pactra Camouflage Grey #SM 13 for the color coat, I sprayed the individual pieces of the model. The parts were first given a light "dusting" and left to dry for a few minutes. This is

done to give the later coats a good gripping surface. When all the parts were completely sprayed, I set them off to the side to dry (for at least 24 hours). I next took the parts of the kit that had to be sprayed in a contrasting grey and masked them off (when needed). This included the ribbed tail section, the rear gun, the rear lower control flap arms and the inside of the rear upper control units. Duro brand primer was used on these parts.

The next step was to paint the insides of the upper and lower control flaps. I first masked off the outside surfaces with tape and then sprayed the parts with the primer.

When the parts were dry, the kit was assembled following the plans. As many of the parts have already been assembled together as units, I found that the kit went together rapidly. With the model assembled, final detailing and weathering was begun.

Using the photographs found in the research books, I weathered the model using the dry brush technique. For this particular kit, I didn't see the need to airbrush any weathering. I find I can get more control by using this method over the airbrush system for many projects. The "laser hits" were weathered with oily black paint over silver. This made for very realistic battle damage and the same method can be used for any spaceship kit.

With the extra work put into the model, you can have a realistic scale model you will be proud to display anywhere. ▲



# BEHIND THE SCENES WITH RAL PARTHA

By PHILIP O. STEARNS

**O**n the banks of the Ohio river in Cincinnati stands one of the giants of the miniature figure business, Ral Partha by name. From a concept by its two founders six years ago it has grown from Glenn Kidd's basement, through two moves, to its present location with 10,000 square feet and twenty five employees. Glenn, as its president, explains that he and Tom Meyers, the sculptor/designer, both felt it was a shame that so few people were really concentrating full time in an area so full of promise as the 25mm war game field. After a few deep discussions they decided to take the

plunge and launched this highly successful enterprise. Both Glenn and Tom are avid games players and both are devoutly dedicated to the creation of the finest products in the field.

But how did the name *Ral Partha* come into existence? I asked. "When the game DUNGEONS AND DRAGONS first came out," Glenn replied, "there was an old wizard in it who emerged with a lot of interesting characteristics and quite human, not all good and not all bad, but very human. The real name of the player, of this wizard, was John Winkler, and he involved himself in all sorts of businesses and en-

terprises while playing. Tom and I decided that with his gracious permission we would name the company Ral Partha Enterprises which would give it a humorous connotation and one very difficult to forget once people had mastered it is pronunciation. By the way, John now works for the company."

My next question involved the number of products directed to the fantasy field, as opposed to the historical, and the reply was amazing. Although the company manufactures more military historical figures, its sales figures show that between 80% and 90% sold are in the fantasy range. Although the



PHOTOS: PHILIPPO STEARNS



**Above Left: A ferocious large Dragon typical of Ral Partha's imaginative interpretation. Above Right: A conan type barbarian confronts a dragon in its lair.**

company stands at the forefront of the fantasy world, it does not create any special figures for any specific game or role playing. Their entire fantasy production is concentrated around Royal Armies of the Hyborian Age which is the basic name of Ral Partha's fantasy line. Within this framework, Tom Meyer and fellow designer, Dennis Mize create any and all fantasy subjects which come to mind.

I was curious to know just what Glenn's opinion was on the future of fantasy gaming as a whole, and whether he thought its popularity would continue. He answered that in his opinion the gamers are really beginning to emerge from their almost enforced closets, just as the miniaturists have done. Glenn believes that any youngster when asked if he indulges in fantasy games will enthusiastically nod his head, while the older people, of say thirty and above, will deny or reluctantly admit it. However, many of the military

war gamers are beginning to drift into the fantasy and role playing games. In any case, even if only 1% of the populace had any interest in the hobby that would represent over a million and a half participants. It would seem that this is a fairly conservative guesstimate of where the hobby is going. The many sci-fi and fantasy films flooding the market at present are also stimulating the hobby. The world always looks for escape from reality, and the fantasy games offer a very illusionary and wonderful means of entering imaginary universes.

"So in answer to your question," Glenn continued, "I really feel that the fantasy game and its figures will certainly be around for a good long time, and that sales will continue to increase as more and more people discover the hobby."

Ral Partha is involved in six of the major convention shows each year. From these they have garnered a good number of awards including several H.G. Wells Awards for the excellence of their figures, the Courier award for their condoterie line as the best historical figures, two strategy awards, and two awards from England. Glenn, naturally, feels that nobody produces a better 25 or 15mm figure than Ral Partha, and that much of the credit for this lies in the hands of Tom Meyer and the design department.

"What we try to do is to produce the best possible figure we can and also to give our customers the best possible service we can. One thing we do, which no other company does, is to take our figures and constantly remake them so as to eliminate any previously discovered flaws in them. The Wind Lord for instance has been redone three times in our attempt to make it better. We make a complete and honest effort to make sure that our figures are of the highest quality."

Another interesting facet of the Ral



**A high priest and his entourage is carried through a fantasy country.**

Partha business is the attitude of the partners towards their employees. Of the twenty five people on the payroll at least twenty are considered part of the "family," which is Glenn's way of interpreting the company attitude. There exists a form of camaraderie in which everyone looks out for the others and work is not just a job. Recently, when an outsider made some disparaging remarks about a new member of the "family" two of the originals were set to practically lynch this individual. The whole workings of this company function in a manner completely outside the normal channels of an American business company.

Tom Meyer, like a number of talented artists, is a private person totally reluctant to talk about himself and the interests which drove him into sculpting. The only thing which he would acquiesce to is the complete revelation of how he works in his chosen medium and that he had no formal art training. After much experimentation he has finally settled on a form of plastic putty strengthened with an armature or matrix as he calls it. The brand of putty he prefers is Duro Epoxee Putty which comes in strips of yellow and blue. When mixed together, of course, it renders a green material. As he says, "This material is very pliable and tends to globulate when left alone when freshly



**The working wheels of Ral Partha from left to right: Sales Director Jack Hesselbrock, Legal Partner Marc Rubin, President Glenn Kidd, Designers Tom Meyer and Dennis Mize.**

mixed. This offers severe difficulties until one familiarizes oneself with its peculiarities. It has a consistency of bubble gum and it has a tendency to smooth itself out. It is still a bit flexible even when it is dry. It holds detail on a molecular level and it can be stretched out so thin that it can almost be seen through. The most important aspect of this putty is to make certain that the underlying matrix has thoroughly dried before applying the final detail

over it for in this manner one can achieve incredible effects in folds of cloth and hair through its pliability. A metal matrix can be partially covered with the first layer of putty but not too thickly, otherwise it will globulate. It is wise to make sure that the putty is smoothed out first, otherwise it will crumble and crack. Also one's tools must be kept constantly wet for the putty will adhere to them otherwise and, as it is non-toxic, one can use one's mouth

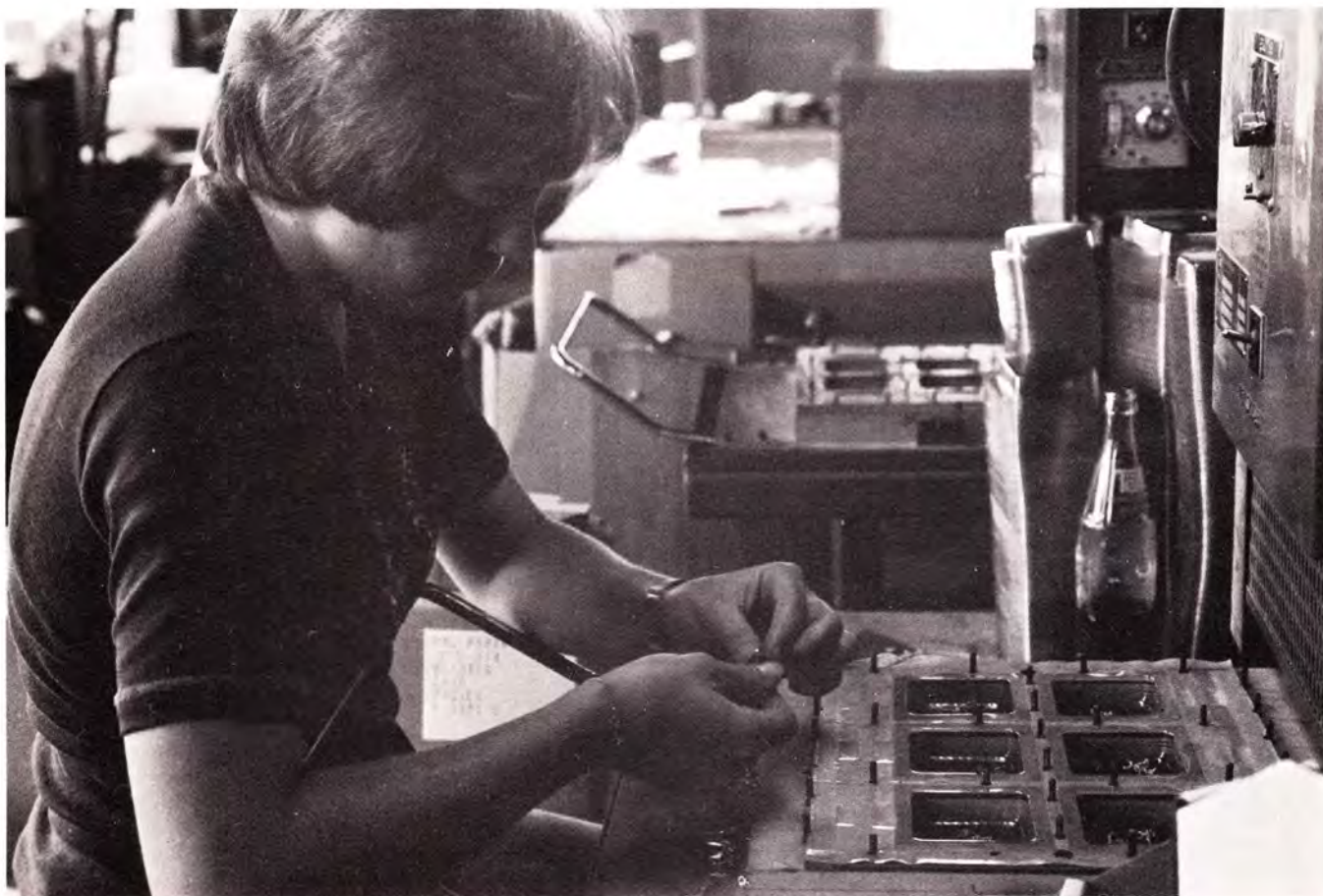

**At Ral Partha craftspeople work in a "family" environment and produce the finest miniatures.**

ANY WAY YOU LOOK AT IT  
GRENADIER DOES IT BETTER



The solid gold line of official 25mm fantasy miniatures  
for Advanced Dungeons & Dragons

**GRENADIER MODELS Inc.**

Box 305, Springfield, PA 19064



**Battle room scenery.**

to keep one's tools moist without fear of poisoning. For making chain mail this putty works better than anything else.

"Once the folds of the garment have been established a small pin is inserted into the material and gently pulled into a crescent. With careful repetition a row can be established on the figure and a return row in the opposite direction until the figure is composed of interlocking links of mail. The most important element in working with this material is time and a great deal of patient care. The one thing to remember is that you only have about an hour and a half before it sets, so great care must be taken not to work on too large an area at one time. Another advantage to the use of the putty is that it eliminates one step in casting, for the putty will stand up to the heat of vulcanizing, the only noticeable difference being that the color of the putty will darken with each insertion in the vulcanizer. The only qualities which could make this material absolutely ideal would be for it to harden when you needed it to be, or that you could keep it soft as long as you were working a figure with it. However, some of its disadvantages can be used to one's own benefit. Take, for instance, its adhesiveness which can be very useful when touched with a dry instrument and then delicately pulled out to create all sorts of surface textures. The



**This single 25mm figure gives an excellent impression of the detail in Ral Partha figures.**

advantages and disadvantages of this material are what you must learn to live with and, in my case, I just can't see myself living without it now that I have more or less mastered its idiosyncracies."

It is an interesting thing to note that both Glenn and Tom hold Tom Loback, last issue's highlighted games modeler, in the highest respect. They feel that his work is done on a more impressionistic plane than theirs. They not only admire it but they are all great friends as well. It certainly is a high recommendation when the two premiere creating companies in this field hold in each other in such high regard.

Ral Partha is unique in its operations as it controls all of the facets within the house itself. It not only manufactures the figures but it has its own art and photography departments, it creates its own advertisements and publicity, and it services the modeling world with the finest products available. The sincerity and integrity of its approach is tempered with a huge amount of fun-loving humor on the part of all its members who cooperate with each other in a high degree of good spirits even under an inordinate amount of pressure. In closing, I would like to say that if you are in search of finest pieces for your fantasy armies or games you have no further to reach than the house of Ral Partha.  $\Delta$

# FANTASY AND SCIENCE FICTION

## GAMES

Great games.

Far-out ideas.

Beautiful play components.

Low prices.

And you can get them by mail!

*RAID ON IRAN: A tense tactical game about the attempt to free the hostages. What would have happened if the commandos had reached the embassy? An alternate scenario lets you try to kidnap the Ayatollah! Only \$3.00.*

**CAR WARS:** Build your future auto with machineguns, flamethrowers, rockets, smoke-screens, and armor — then take it out on the freeway. **DRIVE OFFENSIVELY!** A fast-moving game with road maps and full-color counters for cars, vans, and cycles! Only \$3.00.

**KILLER:** *The first rulebook for the "Assassin Game" that's being played on campuses across the country. 40 pages of gadgets, scenarios, and rules for wiping your friends out . . . without hurting them. A LIVE role-playing game for intelligent, creative, and slightly uncivilized people — only \$5.00!*

**UNDEAD:** The adventures of Count Dracula in London, closely based on the original novel. One player is Count Dracula, hiding his coffins and biting maidens' necks. The other player(s) — one or several — try to hunt him down. The vampire can change his shape — the hunters can recruit new help (even Sherlock Holmes!) A tense battle of wits. \$3.00.

**KUNG FU 2100:** *A science-fantasy game of the far future. Three Terminators — skilled masters of the martial arts — invade the fortress of the evil CloneMaster to destroy him. A simple but unique combat system makes this game a challenge. Only \$3.00.*

**CARDBOARD HEROES:** Full-color miniatures for any fantasy or role-playing game. These detailed 25mm miniatures make great painting guides for lead miniatures — but they're so good (and so cheap) you may never use metal miniatures again. There are four sets: Set 1: Player Characters. 40 figures. \$3.00. Set 2: Brigands, Orcs, and Goblins. 40 figures (bad guys for your games). \$3.00. Set 3: Half-Orcs, Reptile Men, and Kobolds. 40 more opponents . . . \$3.00. Set 4: Animals. 48 assorted beasts. \$3.00.

**THE SPACE GAMER Magazine:** If you play *Dungeons & Dragons*, *Traveller*, *Star Fleet Battles*, *Ogre*, or any other science fiction or fantasy games, this is the magazine for you. TSG gives strategy articles — reviews of new miniature figures and games — designer articles — company news — and much more. And TSG subscribers get free postage on SJ Games orders, as well as other freebies! One year (12 issues) is \$21 Two years are \$39. (Yes, we use a protective mailing cover!) *Non-U.S. subscribers please add \$5 per year for postage.*

*Check your local hobby shop for our games. If you can't find them, we'll be happy to fill your order by mail. (Retail and distributor inquiries are also welcome!)*

**TO ORDER:** Send retail price for all items, PLUS 50 cents postage per item ordered. (If you subscribe to *The Space Gamer* with this order, or if you are already a subscriber, your postage is free.) Texas residents should also include 5% sales tax. Please do not send cash — payments must be by check or money order in U.S. dollars, drawn on a U.S. or Canadian bank. Please allow 3 to 6 weeks for delivery. You CAN charge orders to your Visa or MasterCard (\$10 minimum, please). Include your card number, expiration date, and signature on your order.

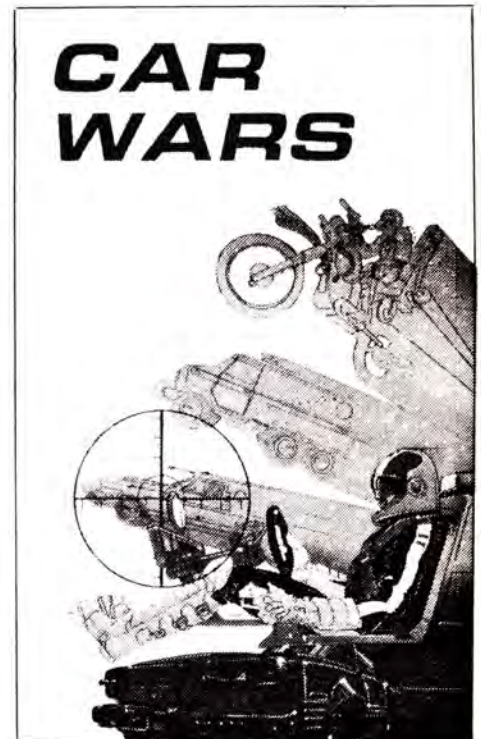

**STEVE JACKSON GAMES**  
BOX 18957-Y  
AUSTIN, TX 78760

# FINDING FANTASY FIGURES

By MIKE KILBERT

**B**y making a few strategically placed phone calls I acquired some excellent examples of miniatures that are available on the market. I selected these examples because they are licensed by manufacturers of various role-playing games for use with their games. A wizard licensed by TSR Hobbies is not necessarily better than someone else's wizard, but it is a wizard that the game company feels matches the ideas and concepts of their game.

The popularity of T.S.R. Hobbies' DUNGEONS & DRAGONS role-playing system has led to the introduction of two separate lines of 25mm miniatures. From Grenadier Models, there is an "Official" ADVANCED DUNGEONS & DRAGONS line which at present includes six full size boxed sets (retail-\$13.00 each), ten half-size boxed sets (retail-\$7.00 each) and two different Action Art sets. The full size and half size boxes have a varied assortment in each box of 25mm unpainted figures. The boxes are titled so that you have an idea of what is included: a Dwarves set, a Specialists set, a Wizard's Room, etc. (Pictured are some examples from their #2004 Halflings set). The Action Art sets do not include as many figures as the full-size box sets but they have paints and a brush for the beginner. These sets are complete in terms of materials for the new modeler.

The other line of figures licensed by TSR Hobbies is THE WORLD OF GREYHAWK line that is being produced by MiniFigs. When Gary Gygax



**Two lovable types by Grenadier Models from ADVANCED D&D.**



**Eisenwerk's fighter and evil giant from TUNNELS & TROLLS.**



**Two fighters from Heritage's KNIGHTS & MAGICK.**



**An avenging angel for KNIGHTS & MAGICK by Heritage Models.**

created his game, DUNGEONS & DRAGONS, he also created a world for this game to be played in. MiniFigs has introduced the figures that represent the countries, places, and people of this fictional world. This world is complete with many countries and nationalities, so the line from MiniFigs runs over sixty different packs, varying in price from \$3.98 to \$9.98. The figures in the picture are from the Wandering Adventurers pack, #43; and from the Amazon Infantry—Hardby, #1. (Both packs are \$3.98.) If you're not playing in THE WORLD OF GREYHAWK, I'm sure that your game could use a pack of Adventures of Amazons.)

Heritage Models has long had a fine reputation for its 25mm figures, it was only a matter of time before they cre-

ated their own fantasy game and added their figures to it. With the introduction of KNIGHTS AND MAGICK, there is not only a new game on the market, but also an extensive line of 25 mm fantasy miniatures. You can buy either their Merlin set or the Knights of King Arthur set as an introductory selection; or you can choose from the blister-packs that are aimed at the experienced modeler or the modeler who wishes to supplement the sets he has already bought. Either way you can't miss with these fine figures.

Flying Buffalo's popular TUNNELS & TROLLS fantasy role-playing system is now more attractive with the addition of these figures produced in conjunction with Eisenwerk. The line is not very extensive now, but the quality

and originality of design make these figures useful in just about any fantasy campaign. The figures in the photos are from pack 44-3 Giant and Armoured Fighter. The set of both figures sells for \$3.95.

Finally, for those of you who have a passion for science-fiction role-playing and who are familiar with TRAVELLER from Game Designers' Workshop, you'll probably like these figures from Martian Metals. These "official"

Traveller figures are well-detailed 15 mm scale. It's hard to imagine that these figures are about the height of a dime, and still have so much detail. (I'm starting to disbelieve their advertising copy that says they're not alive.) **Δ**

## THE ROLE OF THE DICE

**I**n most games there must be some element of chance. Whether you're playing poker, MONOPOLY, or TRAVELLER, chance is an important part of the game. If not for the dice in the MONOPOLY game, you would quickly get tired of playing it because every game would be exactly the same. The dice make each time you play the game different from the time before. By changing the amount that you can move each turn, there is an *unpredictability* that makes the game enjoyable.

Virtually all board and role-playing games use dice to achieve this element of variability. Many people look at a game and say that no skill is involved if it uses dice. Actually, there is a lot more skill involved, since you must deal with constantly changing and unpredictable situations.

Chess, certainly a highly sophisti-

cated game, can easily be played exactly the same way two times in a row. With one player making a move, and the other responding in exactly the same way every time, the possibility that it will end in the same way is high. It is not unusual for chess enthusiasts to recreate great games of the past. Also, many chess books deal only with a specific opening move. There could be no book of openings in MONOPOLY, since the first move could be anywhere from 2 to 12 spaces. Every subsequent move could be just as variable.

Card games are no different. Each time a deck gets shuffled, the cards are different from the time before. If luck means that no skill is involved, then the argument would follow that no skill is involved in *any* card game.

Most people are familiar with the dice that come in most games: little

cubes with 1 to 6 spots on each side. But have you ever seen 20-sided dice, or 4-sided dice? The development of games has created innovations in the shape of dice. There are 4-sided, 8-sided, 12-sided, and 20-sided dice to go along with the traditional 6-sided cubes. These other dice give the designer a wider range of unpredictability to build into the game. With "normal" cubes you can roll 1 to 6 with one die or 2 to 12 with a pair. Just imagine what you can do with 10-sided dice—the numbering system is 0 to 9. You can roll 0 to 9 with one die, and 0 to 18 with two. Or, you can use the two rolls together to arrive at a percentage. A 4 on one and a 5 on the other would mean 45%, etc. The instructions might say—roll higher than 60% and you can get out of jail.

*Caution:* When you buy a game make sure that either it has dice in it or, if it requires special dice, you can easily purchase a set. **Δ**

## MONSTER MINIATURES



The night is black and stormy. You sit up in your bed as lightening cracks the sky. Eerie sounds invade your room—heavy footsteps in the hallway, the flapping of batwings at your window, a horrifying, half-human howl! You feel an icy grip close in around your neck as you lunge out of bed and flip on the light. And there they are—the Wolfman, Dracula, Frankenstein and the Mummy!

These beautifully crafted miniatures stand over 2½ inches tall (actual size shown) and are molded in durable pewter. For only \$24.95 each (and this price includes postage) you can add these finely detailed collectors' items to your private collection.

Or, for only \$5.98 (plus \$1.50 postage and handling) you can get the same fine craftsmanship molded into white metal.

**SPECIAL OFFER.** All four pewter miniatures \$79.95, postage included.

Send your check or money order to **MONSTER MINIATURES, STARLOG PRESS, 475 Park Avenue South, New York, NY 10016 DEPT. FM4**

### PEWTER

- THE WOLFMAN \$24.95
- DRACULA \$24.95
- FRANKENSTEIN \$24.95
- THE MUMMY \$24.95
- SEND ME ALL 4 PEWTER MINIATURES FOR \$79.95!

### WHITE METAL

- THE WOLFMAN \$5.95 + \$1.50 postage
- DRACULA \$5.95 + \$1.50 postage
- FRANKENSTEIN \$5.95 + \$1.50 postage
- THE MUMMY \$5.95 + \$1.50 postage

TOTAL AMOUNT ENCLOSED \_\_\_\_\_

NAME \_\_\_\_\_

ADDRESS \_\_\_\_\_ CITY \_\_\_\_\_ STATE \_\_\_\_\_

ZIP \_\_\_\_\_



# ROLES GAMESPEOPLE PLAY

Soon after the first issue of FANTASY MODELING got into people's hands we were immediately stormed with letters asking for more information about role-playing games.

There are many games on the market now, and it may seem bewildering. But there really is some way to get a handle on all of this. Let's start with the basics. All role-playing games are alike in terms of their play. You can be a character or a gamemaster.

Some people think of the gamemaster as the "Creator"—because he or she has created a world for the other players to explore. A world that is inhabited by the good, the bad, and even the ugly; a land filled with traps to capture the unsuspecting; a setting where danger lurks behind every door; a place where you must use all your abilities if you are to succeed. It may be populated by fire-breathing dragons and evil wizards, or you may find yourself at the mercy of an evil alien somewhere in deep space. You may find a buried treasure on a beach or some hidden jewels in a frontier town. Name your place, name your time, and you can almost be sure to find a game that is perfect for you. Explore the Gamemaster's world and see if you can discover the mystery of it.

If you decide to be the Creator, then you must expect, and be willing, to do a

lot of hard work to "flesh" out this world. There should be a real challenge for all the players. But you must keep in mind that if the challenge is *too* hard there may be no survivors to come back next time. In the past the job of creation was much harder, today there are many products on the market that

make the job a lot easier and more enjoyable for the Creator. I'll be discussing some of these items later on.

The second part of the creator's job is to direct the players through the adventure. For some, this is where the real fun comes in. This is where the gamemaster proves whether or not he has



created a playable and enjoyable world. He hides a map of his world behind a screen and drives the other players crazy with devious set-ups and nefarious schemes. Actually, the gamemaster can make or break any game system. His is a crucial part of any game, not intended for the inexperienced. Become a good player before you seriously consider trying it. (Some games like TUNNELS & TROLLS don't need a gamemaster. They are the exception.)

Once a player chooses the character that he wishes to be, he will then "roll up his characteristics." The higher the number, the more he will have of that attribute. Most games include factors like strength, endurance, intelligence, charisma, leadership qualities, weapons abilities, etc. as those things you will want your character to possess. If he doesn't have too much strength, you better make sure that he is well-armed, or that he avoids all sorts of trouble. You better hope that he has enough intelligence to get out of danger.

When you first start playing make sure that the gamemaster is well aware of your game experience. The more experience that you have, the more challenging that world should be. On the other hand, if you're a real novice you don't want to find yourself blown out before you even get started. It's no fun for anyone to be out of the game before the action gets in gear. If the ingredients are right: good gamemaster, a world that will challenge you, a character that you want to play, and a good chemistry among all the players, then you'll understand why these games are so popular.

I can't emphasize enough that this chemistry is very important to the players. Most games that we are used to playing involve winning and losing. In a situation where winning is most important you don't really care who you play with as long as you win. Part of the attraction of a RPG is that nobody "wins" or "loses."

You can succeed at exploring the world and achieving some objective, but it's never a matter of who got the most points. You never win at puzzles or solving mysteries. There is just the satisfaction of having done the best you could and succeeding at that.

(There are many people who feel that the idea of *winning* is not as popular as it used to be, and because of this, RPGs have become more popular. They very well may be the games for the Eighties.)

Remember, the chemistry of the players themselves is important to the success of the game in more ways than one. Of course you can't enjoy any game if you don't like the people that you are playing with. That's true for Poker, MONOPOLY, SCRABBLE, or TRAVELLER. But another difference in RPGs is that the players can succeed only if they *combine* their talents

and skills. A large part of these games is the social interaction between the players. To solve the mystery of another world the players must be willing to work together as a sort of roving party of adventurers. Any world should be so tough that it forces the players to pool their resources. It's a good chance for you to meet some new people and to really understand how they think.

In most games it's you against the game and all it throws at you; plus you must deal with the other players that are trying to defeat you. Think of MONOPOLY; there's jail, Luxury Tax, Chance cards, Opportunity cards, etc.—all as obstacles. Besides that, the other players are trying to take away all your money and property. It's you, by yourself, against the world. In RPG, you're not alone.

The letters we get represent a wide cross-section of people. Some of you have already played role-playing games, some of you have never played, but the questions were pretty much the same: What other kinds of games and supplements are available? Where can

I get these games? How are these games different from each other? And the most asked question: Which game is the best game?

The following will be a partial listing of descriptions for many of the more popular games. New games are released constantly, so already this list is outdated. But, it should give you some idea of what's available. Of course, I can't answer which is the best game—that depends on you. It's like asking someone which is the best ice cream, vanilla or chocolate? Each game is professionally produced and each has its own special characteristics.

(For those of you that are looking for an evaluation of the games, I have asked my friend Vinny Amella to give me a quick comment about each. This will add some impartiality since Vinny has no association with any company. You might get the idea that I'm trying to please advertisers. But more important than that, Vinny is an acknowledged expert who has appeared on TV, radio, in various newspapers and magazines):



<b>Manufacturer</b>	<b>Title/Designer</b>	<b>Description/Comments</b>
Avalon Hill Games 4517 Harford Rd. Baltimore MD 21214	GUNSLINGER	Old West: Soon to be released.
Chaosim P.O. Box 6302 Albany, CA 94706	RUNEQUEST (\$12—book- let, \$20—boxed.)/Steve Perrin, Ray Turney	Fantasy: Boxed version includes rule book, dice, etc. "Possibly the best magic system of any fantasy RPG today. Only game in which Aardvarks and ducks can stand beak to snout on equal terms. Popular following in CA.
Excalibre Games P.O. Box 29171 Brooklyn Center, MN 55429	ADVENTURES IN FANTASY (\$25)/Dave Arneson	Fantasy: Three large rules booklets included. "This is the game Dave Arneson intended D&D to be. The rules are clearer, more precise, and more together than the original D&D set.
Fantasy Games Unlimited 240 Mineola Blvd. Mineola, NY 11501	BUNNIES AND BURROWS (\$6)/ B. Dennis Sustare, Scott Robinson	Much like rabbit characters from <i>Watership Down</i> : Single rules booklet.
	CHIVALRAY & SORCERY (\$10)/Ed Simbalist, Wilf Backhaus	Medieval Fantasy: "The only fantasy RPG to recreate Medieval Europe as it might have been. Long, complex rules in small type are the only drawbacks hampering this game from being better than D&D."
	FLASH GORDON AND WARRIORS OF MONGO (\$6)/Lin Carter, Scott Bizar	Sci-fi: Single rules booklet.
	GALACTIC CON- QUEST (\$4)/ Adam Gruen	Sci-fi: Single rules book, includes rules for a full campaign.
	GANGSTERS (\$10)/ Nick Marinacci, Pete Petrone	Roaring 20's: Criminals vs. Crimebusters. Boxed with several booklets. "Edward G. move over. You're no longer the toughest guy in town. With GANGSTERS anyone can take you. This game not only recreates underworld crime, it also concerns modern terrorist and anti-terrorist combat."
	LAND OF THE RISING SUN (\$18)/Lee Gold	Feudal Japan: Samurai struggle for control. Extensive boxed format. "Designed to be compatible with CHIVALRY AND SORCERY. Possibly the only game to correctly portray ancient Japan. Don't be daunted by its long, complex rules. Once you've played it a couple of times, it is very smooth."
	MADAME GUILLOTINE (\$4)/Game Testers Group	French Revolution, 1789: Re-live the reign of terror.
	ODYSSEUS (\$5.50)/ Marshall T. Rose	Mythical Greek Gods: Single rules booklet.
	SKULL AND CROSSBONES (\$12)/ Gerald Scypura, Anthony Le Boutillier	Piracy: Boxed format.
	SPACE OPERA (\$18)/Ed Simbalist	Sci-fi: Extensive boxed set. "Challenges GDW's TRAVELLER as a sci-fi RPG."
	STARSHIPS & SPACEMEN (\$7)/ Leonard Kanterman	Outer Space: Rule booklet included.
	VILLAINS AND VIGILANTES (\$6)/ Jeff Dee, Jack Herman	Comic book Superheroes: Single rules booklet, with comic-style cover.
Flying Buffalo P.O. Box 1467 Scottsdale, AZ 85252	TUNNELS & TROLLS (\$8.95—booklet, \$14.95—boxed)/ Ken St. Andre	Fantasy: No gamemaster required. Can be played solo. Boxed version includes rule booklet. "The only RPG that can and should be played solitaire."

Manufacturer	Title/Designer	Description/Comments
	MONSTERS! MONSTERS! (\$4.95)/Ken St.Andre	Fantasy: Single rule booklet. "The Orcs and the Goblins are the good guys. The Elves and the Humans are the bad guys."
Game Designer's Workshop 203 North St. Normal, IL 61761	EN GARDE (\$4.95)/ Darryl Hany, Frank Chadwick	16th Century Europe: Three Musketeers. "If you want to play one of his majesty's musketeers or Cardinal Richilieu's guards, then EN GARDE is for you. Short rules and simple combat make this game a rival to some of the better known games."
	TRAVELLER (\$11.98)/ Marc Miller, et.al.	Sci-fi: Boxed set with three rules booklets. "The best sci-fi RPG in existence. Though this game has been around for a short while, it is <i>the</i> rival to D&D. Watch out Gygax. This game is catching up real fast."
Gamescience 01956 Pass Rd. Gulfport, MS 39501	EMPIRE OF PETAL THRONE (\$30)/M.A.R. Barker	Fictional: Aztec-type world created for game. High quality maps and booklet.
	SUPERHERO 2044 (\$7.98)	Future: Comic book heroes come alive.
Heritage Models 14001 Distrib- ution Way Dallas, TX 75234	KNIGHTS & MAGICK (\$19.95)/ Arnold Hedrick	Medieval Fantasy: "The most complete set of rules for any game system. Includes campaign and miniature rules."
International Gamers Assoc. 5465 Atlantic Ave. Long Beach, CA 90805	ARDUIN GRIMOIRE (\$9.50—vol.)/ David Hargrave	Fantasy: Three volumes are needed to complete the game. "Though this is billed as a game in its own right, it is best used as a supplement to D&D and The Fantasy Trip."
Metagaming P.O. Box 15346 Austin, TX 78761	THE FANTASY TRIP (\$4.95 per book)/ Steve Jackson	Fantasy: Three booklets for complete game systems—The Labyrinth, Advanced Wizard, and Advanced Melee." At \$4.95 per booklet this is the best value that can be recommended to both novice and old hand fantasy role-players alike."
Phoenix Games (no longer producing games.)	BUSHIDO (\$10)/ Paul Hume, Bob Charrette	Feudal Japan: Includes two booklets.
	SPACEQUEST (\$10)/Paul Hume, George Nyhen	Sci-fi: Only one rule booklet.
Simulations Pub. 257 Park Ave. So. New York. NY 10016	COMMAND/ Eric Goldberg	World War II: Boxed game, complete with rules maps, etc. "This game is designed to introduce the hard-core boardgamer to RPG systems. This game contains no counters. All movement is tracked by players on their own maps of the game area."
	DALLAS (\$9.95)/ Jim Dunnigan	Modern Texas: Based on the TV show. "Everyone's got a little J.R. in their heart. With this game you can recreate many of the TV episodes. Well-written, short, rules and actual scripts are included."
	DRAGONQUEST (\$12)/ Eric Goldberg	Fantasy: Three rules booklets and map in boxed set. "Probably the best man-to-man gaming system known."
TSR Hobbies P.O. Box 756 Lake Geneva, WI 53147	BOOT HILL (\$10)	Old West: Includes rule book and map in box.
	GAMMA WORLD (\$10)	Sci-Fi: Includes rule book in box.
	TOP SECRET (\$10)	Modern: "Spies and Counterspies."
	DUNGEONS AND DRAGONS/Gygax  1. Collector's Ed.  2. Basic Set (\$10)  3. Basic Set (\$12)  4. Expert Set (\$12)	Fantasy:  "The Original." This boxed set contains three books.  "Since superseded." Contains rule book for the beginning adventure. The new set includes an improved rule book and dice for the beginning adventure. Includes innovations to further expand the new Basic D&D format.

# MODEL ROCKETRY AND FAR OUT SHOTS

By MICHAEL A. BANKS

**T**his time out, we'll kick things off with a discussion of one of the more interesting aspects of model rocketry—aerial photography via a rocket-borne camera.

The earliest experimental activities in this area were undertaken in the early 1960's. Small, lightweight Japanese cameras were used, mounted on model rockets in whatever manner seemed most feasible. Shutter activation was accomplished by the use of a string which released the shutter when the model rocket engine's objection charge was activated. Related activity included one instance in which a spring-wound 8mm picture camera was flown onboard a model rocket.

In 1965, the first commercially-produced model rocket camera was introduced. This was the "Camroc," manufactured by Estes Industries of Penrose, Colorado. The Camroc was basically a cylinder, approximately 1½ inches in diameter, which comprised the front half of the fuselage and "nose" of the rocket. The camera's lens was located at the forward end of the cylinder, in place of the usual model rocket nose cone. In flying the Camroc, a long delay time was used between burnout and ejection, to permit the rocket to turn "nose down" before snapping a photo. Shutter activation was, as with earlier attempts, by way of a string which released the spring-loaded shutter at ejection.

Camroc took one photo per flight, using a circular, 1½ inch diameter negative which had to be handled with a special disk cannister to prevent exposure. Photo buffs may be interested to know that the film used was Tri-X, which had to be pushed to ASA 1200 in processing.

In 1970, Estes introduced "Cineroc," a motion picture camera which used Super 8mm cartridges to record model rocket flights from the vantage point of looking from the nose and over the fins to the ground. Each flight provided approximately 40 seconds of projection time.

Unfortunately for hobbyists and experimenters, Estes stopped production of both the Camroc and the

Cineroc in the mid-1970's, due to a loss of parts suppliers and the wearing out of the plastic molds used to manufacture the cameras.

Model rocketeers were left without a viable system for aerial photography until 1978, when Estes began marketing its "Astrocam." The Astrocam



PHOTOS MICHAEL A. BANKS

**Astrocam photos of horizon (above), houses (below).**

proved to be a vast improvement over the Camroc because it uses a 110 film cartridge in place of the old circular negatives, and its photos are in color.

The Astrocam and its booster are sold as one unit, and the camera actually comprises the rocket's nose cone. Shutter activation is achieved in the same manner as it was with the Camroc, and provisions are made for winding the film and for protection against accidental exposure of frames with a cover which slides over the shutter opening.

The photo is taken through a mirror, mounted in the hood projecting from the slide of the camera (see illustration). The lens, made from an acrylic plastic, is mounted horizontally. Like the Camroc, the Astrocam takes a

photo while the rocket's nose is pointed toward the ground.

Early Astrocam used a shutter speed of  $1/1000$ th of a second, but all currently available models have a shutter speed of  $1/500$ th of a second. Even the lower shutter speed requires a fast film, so you should always use ASA 400 film, as specified.

Construction of the Astrocam and its booster is pretty straightforward. The booster requires no painting, and has plastic fins, so it can be assembled with a minimum of time and effort. The camera presents few difficulties, but you should read through the assembly instructions at least once before starting assembly. It is also very critical that no glue be dropped on the lens during its installation, so take

care in this step and follow the instructions.

Flying the Astrocam/Booster configuration is fairly simple, though it is advisable to keep a checklist and review it before each flight. Once the rocket is on the pad and the wires to the launch controller connected, the shutter should be "cocked," per the instructions, and the "light lock" over the shutter aperture released. This sounds simple, but many rocketeers have forgotten to release the light lock and thus wasted a flight.

After flying the Astrocam, it is advisable to immediately advance the film, so you don't forget and end up with a double exposure.

The recommended engines are C6-5 and C6-7. The C6-5 supposedly will

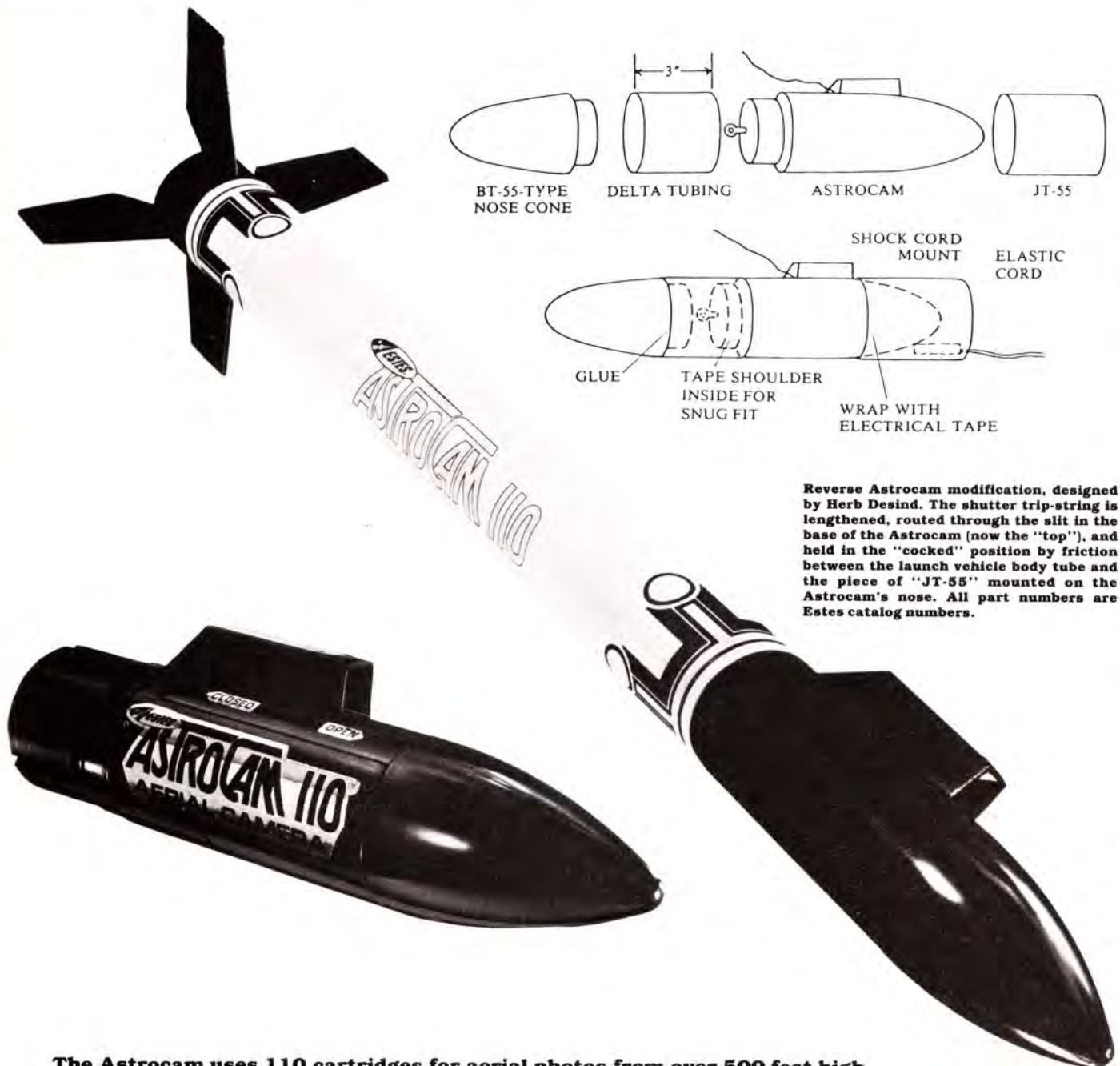

ILLUSTRATION: HERB DESIND AND THE MODEL ROCKETEER

PHOTO: ESTES INDUSTRIES

**The Astrocam uses 110 cartridges for aerial photos from over 500 feet high and can be launched on the Delta II.**

give you a horizon shot, but, more often than not, the result will be a vertical. The C6-7 will also provide a vertical shot, but at a much closer distance, with the potential for problems with parachute deployment. The problems stem from the fact that, during the extra two seconds, the Astrocam picks up a good deal more speed (32 feet per second<sup>2</sup>). This can cause shock cord separation, a torn parachute, or even a gaping hole in the 'chute due to the rocket ripping right through it!

If you want low-altitude flights, B-14 or B-8 engines will provide just enough power to get the Astrocam up to 400 feet or so, and a 5 second delay will prove just right for a vertical shot. A 3 second delay may get you a low-level horizon shot, but it is more likely that it will expose the frame to blue sky and clouds, as the rocket will still be

coasting upward.

Very high-altitude shots may be obtained using the D-powered booster provided by Estes as a separate kit. The kit is called the "Challenger II," and is a single-stage bird with parachute recovery. It is suggested that a large hole be cut in the 'chute at its apex, to facilitate recovery. Otherwise, the rocket may drift for a mile or more before coming to rest (probably in a tree!). An alternative method of recovery is to use a streamer, preferably one 6 inches wide and 8 to 10 feet long. With the streamer, the rocket will descend at a much faster rate, with very little drifting, but still slowly enough to prevent damage to the camera.

(The Astrocam, by the way, is quite sturdy. Mine has fallen from a distance of 200 feet onto a grassy field with no damage. It also hung in a tree for three days, through 2 major rainstorms, and

still yielded some excellent prints.)

Those interested in still higher-powered flights may wish to use E or F engines, or 2-stage or cluster configurations. In constructing a custom launch vehicle for the Astrocam, you may want to obtain an extra Challenger II kit, as the body tube in this kit is the only one available from Estes which fits the Astrocam (other than the "Delta II," which comes with the Astrocam). An alternative is to obtain the "Phoenix Bird" kit from Centuri, which contains the same body tube, or to order Centuri's body tube #6010 (series 13).

If you are new to the hobby, you should build and fly the Astrocam and several other kits before attempting to build your own design. In any case, it is advisable to obtain and study the manufacturers' manuals on model rocket design, or books with similar information, before constructing and flying your own creation.

A couple of final tips on flying the Astrocam. Whatever your recovery system, (parachute, streamer, etc.) *build it strong*. The Astrocam will be traveling downward at a high rate of speed when the parachute ejects, so a heavier than usual shock will have to be absorbed. Also, if you are flying in any type of wind, it is a good idea to tilt the launch rod *slightly* into the wind, so that the rocket will drift back into your recovery area.

If you want to avoid parachute problems altogether, and obtain some unique low-altitude shots, you may want to try the "reverse Astrocam" technique. Flying in this configuration requires pointing the optics hood and mirror toward the ground at liftoff by mounting the camera backwards in the booster. The camera should also have a short piece of body tube and a nose cone attached to its base ("top" in this configuration), to lower wind resistance.

The plan shown here will give you a good basic launch vehicle for reverse shots. Designed by Herb Desind, a Maryland rocketeer, this configuration has been flown successfully on numerous occasions.

This design should be flown with a 3- or 5-second delay time.

Now, you may be wondering, after I get all of these nice aerial photographs, is there anything I can *do* with them? The answer to that question is really quite complex, since the entire subject of aerial photo-interpretation is more than a little complex. Still, I'll give you a few ideas here.

For starters, it is possible to analyze the flight performance of the booster rocket. A photo taken with a reverse Astrocam may reveal an erratic flight path, and engine malfunction, or other problems.

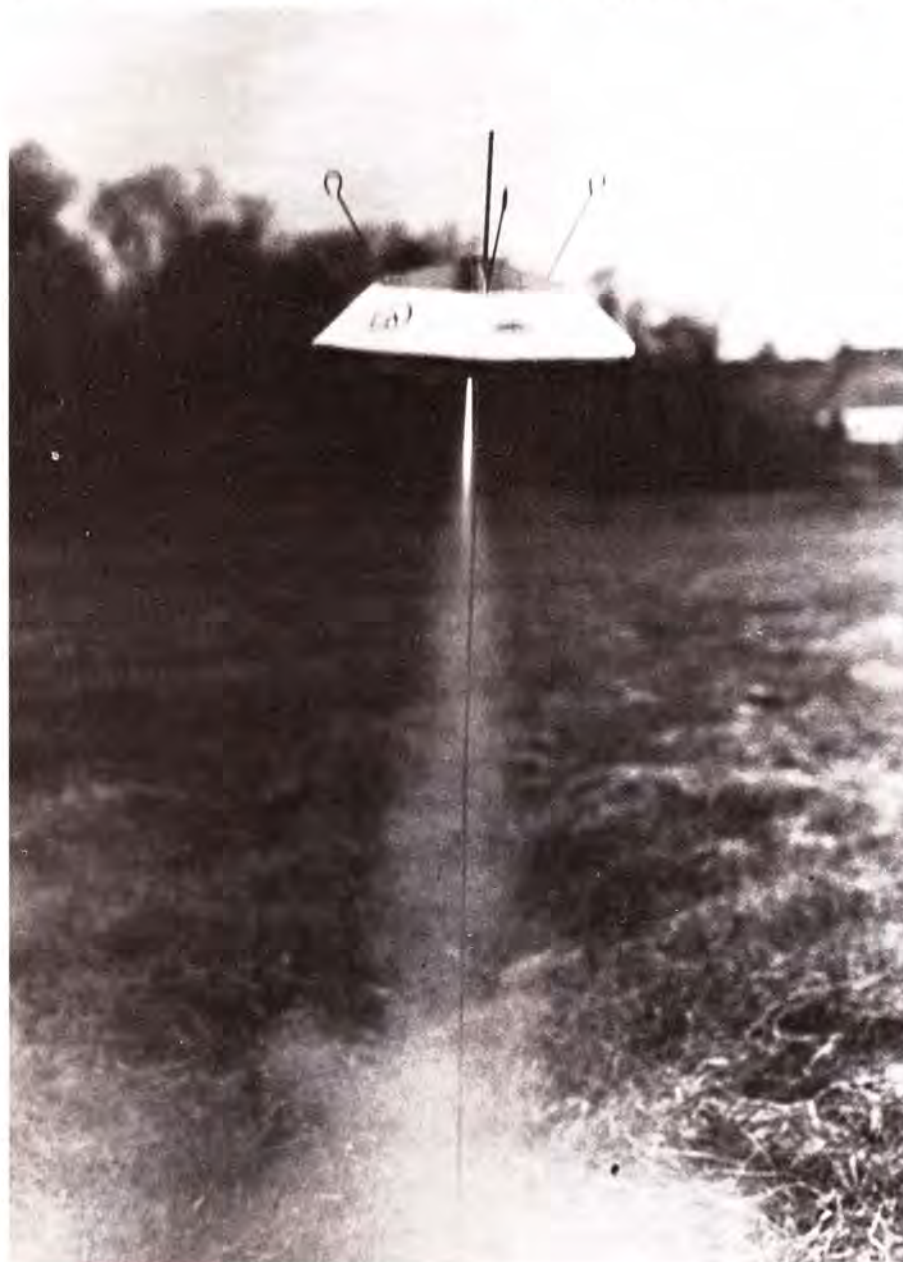

**Centuri's Flying Saucer, looking very much like the real thing, blasts off the launch pad.**

It is also possible to determine the altitude from which the photo was taken, using a simple formula:  $H = \frac{OI}{F}$

- H = Height of camera above the area photographed
- O = Size of a known object in the photograph
- I = Size of image of known object on negative
- F = Focal length of lens

In the case of the Astrocam, F is a constant: 30mm. Substituting some fictional values for the other factors (O = a wall 3.359 meters in length, which is converted to millimeters—3359 millimeters, I = 0.6 millimeters, as measured on the negative.) We have the following:  $H = \frac{3359 \times 30}{0.6}$ , or  $H = 167950$  mm, or 167.950 meters. In feet, that's a shade over 499.

This formula can be transposed to determine the size of objects on the ground as well, if the altitude of the camera is known. The formula for finding the size of objects on the ground is:  $O = \frac{HI}{F}$ .

Other possible applications for aerial photography include studying plant growth on and below the surface of lakes (comparing the varying colors), checking farm crops for evidence of disease, and observing atmospheric effects of pollution.

Late Spring, Summer, and early Fall are the best times of the year to make aerial photos, by the way. This is because the albedo (reflectivity) of the Earth is at its highest, due to favorable angles of the Sun.

If you're new to the hobby of model rocketry and are looking for a good basic guide on building and flying, there is a new book available which is just what you are looking for. *The Basics of Model Rocketry*, by Doug Pratt, is one of the nicer beginners' books to come along recently. The book is printed in an 8¼ inches x 11¼ inches format, with 48 pages and a beautiful color cover. Heavily illustrated, the book covers everything from beginning and advanced construction techniques to science and competition. Look for it at your local bookstore or hobby shop, or contact the publisher, Kalmbach Books, at 1027 N. Seventh St., Milwaukee, WI - 53233.

Static spacemodelers will be interested to know that the National Association of Rocketry is in the process of creating a program for their branch of the hobby. Plans include sanctioned competition at various meets, an information and skill development program, and information exchanges. The program is still under development, and those interested should contact the NAR for membership information.

### New Products

If you are looking for something "different" to fly, check out Centuri Engineering Co.'s "Flying Saucer." This is one of the most unique model rockets to come along in years, and is among the very few flying saucer models in existence. The accompanying photo will attest to its faithfulness in design to the "prototypes" so often reported (the photo is occasionally mistaken as that of a "real" UFO).

For those of you who enjoy more conventional model rockets, Estes Industries also has something different. Their "Galactic Pirates"—Patrol Cruiser Excalibur and Dragon Ship 7—are right out of the pulp era. Their appearance would make them at home in a 1930's Buck Rogers strip or on the cover of *Planet Tales*, circa 1935.

If more futuristic designs are your taste, Canaroc Industries have introduced their "Starfleet" line, with the Starcruiser Warlock, Starfighter Scorpion, and Starship Antares.

The best feature of all of these kits is the fact that they lend themselves easily to "kitbashing" or custom modification. Your imagination is the only limit to creating some truly unique flying models.

Canadian readers, take note. There is now an organization exclusively for

Canadian rocketeers. Known as the Canadian Association of Rocketry (CAR), the group's purpose is similar to that of the NAR in the U.S. i.e., the CAR sponsors contests, publishes a newsletter, issues safety regulations and standards, and selects world championship teams, among other activities.

That's it for this issue. Next issue, we'll discuss flying Space Shuttle and aircraft models, along with flying tips and some special announcements. Fly 'em high!

### FOR MORE INFORMATION

The list following includes all organizations and companies mentioned in this column, and is provided for your convenience.

CANADIAN ASSOCIATION OF ROCKETRY (CAR), Suite 302, 151 Slater Street, Ottawa, Canada, K1P 5H3.

CANAROC, 43 Hanna Ave., Toronto, Ontario, Canada, M6K 1X6.

CENTURI ENGINEERING CO., INC., Box 1988, Phoenix, AZ - 85001.

ESTES INDUSTRIES, INC., Box 227, Penrose, CO - 81240.

KALMBACH BOOKS, 1027 North Seventh St., Milwaukee, WI - 53233.

NATIONAL ASSOCIATION OF ROCKETRY (NAR), 182 Madison Dr., Elizabeth, PA - 15037. △

**RuneQuest**  
*The popular, top-rated role-playing game.*

**Engage & Destroy**  
*Contemporary armored warfare miniatures rules.*

**ELRIC!**  
*Role-playing and miniatures rules.*

**VIVE L'EMPEREUR**  
*Grand strategy Napoleonic miniatures rules.*

**chaosium inc.**  
P.O. Box 6302-FA Albany, California 94706

Please write for a free catalogue. Dealers terms upon request.

## THE MILITARY FIGURE COLLECTORS OF AMERICA EXHIBITION

By PHILIP O. STEARNS

In the military miniatures field the impact of Fantasy Modeling is just beginning to make itself felt, judged by the number of entries at this year's American *premiere* show and competition. The annual Military Figure Collectors of America show has become synonymous with the best that this country has to offer in the figure world since 1936. It is at this venue that Masters and Grand Masters of the figurine are chosen. Not only is the show the most

prestigious, it also garners the largest assemblage of international manufacturers and traders under one roof at one time. It is *the* must for all modelers. So it was with great satisfaction that I found our own area of modeling raising its head at a far greater level than ever before. The quality of fantasy entries was among the best in the entire show, with our friend the Rev. Spencer van Gulick once again leading the parade by winning the boxed diorama competition

with a fascinating, new work of art.

Van Gulick created a marvelous view of a pirate gloating over his newly discovered buried treasure while a giant spider prepares to surprise him. John Trotta, who actually won the Sci-Fi award, had a very outstanding scratch built vignette with an alien space creature entitled "Unit Yellow." Other participants were David Millman, Mike Pierce, Murray Richter, Tom Holtz, Phil Bracco and your editor, all of whom en-



**Top right: Murray Richter's interpretation of "Star Trek." Top left: Grand Master Joe Berton's magnificent "Revolt in the Desert." Bottom right: David Millman's "Droids and Snow Speeder." Bottom left: Mike Pierce's colorful "Major Terri and Vehicle."**

PHOTOS: LANE STEWART

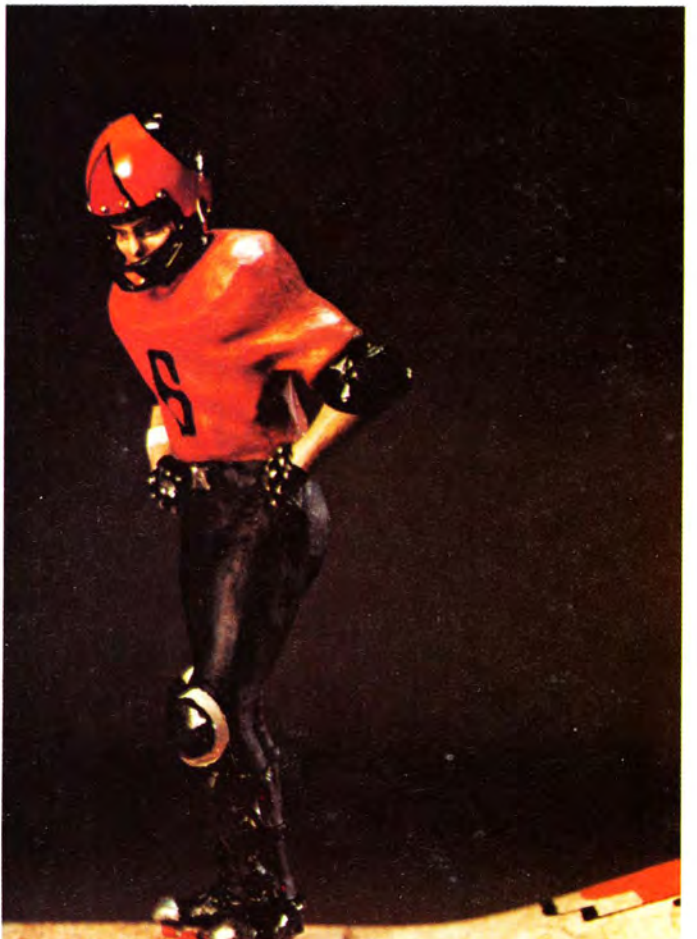

**Top right:** Philip O. Stearns' version of the superior model, "Thor." **Top left:** John Trotta's award winning scratch built robot "Unit Yellow." **Bottom right:** "The Devil with his Victims" modeled by Tom Holtz. **Bottom left:** David Millman's superb rendition of "Jonathan E" from roller ball.



**SPECIAL EFFECTS  
ADDED TO ANY PHOTO!**

Send \$2 for complete catalog. Send \$5 & snapshot (returned unharmed) for super-sample and catalog! Even poor photos look great--at MIDNIGHT! MIDNIGHT GRAPHICS, Dept. C-4, 440 Collfax, Box 3, Palatine, IL 60067.

**Sunfire Seven Movie Miniatures**

Limited Collection of Rare SF Model Kits: Old Trek & More  
Send \$1 for your Catalog Flyer  
SF. 7M P.O. Box 2644  
Paducah, KY. 42001



**SHADOW STAR**

Catalog listing over 1000 SF & F games and miniatures. Send \$2.00 for postage and handling (refundable with 1st order) to:

**Shadow Star, P.O. Box 6815-F  
Bellevue, WA 98007**

**NOW, 25MM ACTION-POSED  
FANTASY FIGURES  
SO REAL YOU THINK  
THEY'RE MOVING!**



Heroes, villains, barbarians, women and monsters in action poses, along with special characters such as left-handed fighters. Not only do we have the newest and best line of figures, we

also have micro space ships, solo dungeons and playing aids, naval models, SF and fantasy books, games, dice and much, much more.

Our 40-page, illustrated catalogue has thousands of fantasy, SF and wargaming items. Hundreds more than anyone else. To obtain this great catalogue, send 40¢ for postage to: AT-PAK, 314 Edgley Ave., Glenside, PA 19038. DEALERS CALL (215) 887-3876.

**\*INCLUDE THE COUPON AND GET A FREE FIGURE**

**ONE FREE**



**FIGURE**



**This 1/60 scale robot was created by Murray Richter from a Japanese Bandai kit. It includes extra rail road model light added by Murray in the helmet.**

joyed the flights of imagination into those nether worlds of fantasy. Although it is not fantasy in the strictest sense, Joe Berton created a sensational piece in the Grand Master class which I feel must be included in our publication with his "Revolt in the Desert." Working entirely with Historex, Heller and Airfix pieces, Joe managed to create the Atmosphere and the look of those fierce camel mounted warriors to which he is so devoted. It might be interesting for you to know that he bought a camel saddle from his guide when he was in Egypt last year. One of my favorite pieces was David Millman's "Jonathan E" from the film *Rollerball*. It is very simple yet it conveys all the excitement of that interesting film. Tom Holtz gave us an eerie conversion of the Devil and some of his victims, while Mike Pierce was not afraid of pretty virulent colors in his vignette of Major Terri with her

amazing looking space vehicle. Murray Richter found a very appropriate manner in which to depict the two Sander-son figures of *Star Trek* which he created for Heritage Models, as well as the very impressive robot which graces our cover made from a Japanese Bandai kit from a TV series there called *Gundam*. And finally the imaginative manner in which Phil Bracco did his scratchbuilt version of the Mongol retrieving his arrow was particularly inspiring.

Altogether I am happy to say we Fantasy Modelers are beginning to create a small world for ourselves. With all of your continued support at these major shows I hope to see us surge ahead in popularity and creativity. There is only one limitation to our efforts and that simply is the lack of imagination. So I exhort all of you to get behind your modeling efforts and participate in every competition you can. △

# COLLECTABLES

**A**mong this month's collectables we have included some absolutely super 25mm figures which we felt offered such marvelous opportunities for the diorama builder that they should be considered in this section. That is

why we are recommending these Citadel Miniatures and we feel sure that after you have seen them you will agree with us, which is not to say that they are not equally advantageous to the gamer. △



**Above:** a further addition to the Atlantis line from Phoenix Model Developments and the hands of Tim Richards includes everything, even black patent leather. **Right:** Even the world of miniatures has been rallying around the Royal Wedding (also from Phoenix).



**Left:** Gateway Hobbies introduces three new soldiers from Vietnam by sculptor Bill Merklie. **Bottom Left:** Monarch Miniatures includes two new Gladiators by Villey Preaterghast in 54mm and (bottom right) a couple of new presentations in the Bugle and Guidon line, an Indian standing over a trooper with his scalp in his hand.



# COLLECTABLES



Little Generals under the guiding hand of Ron Hinote brings us a superb 120mm Mountain Man and two splendid 54mm fantasy creatures .





# FANTASY MAIL ORDER



For the largest selection of 54mm and larger fantasy figures and vignettes. A complete catalog/listing is now in preparation for October release. Price \$1.50.

## The Military Shop

Lakewood Shopping Center Mall Store No. 128  
5234 Pepperwood Ave., Lakewood, CA, USA 90712  
Tele: (213) 630-5556



From Citadel Miniatures of Great Britain and Cincinnati we have some really outstanding 25mm figurines including diorama accessories. Δ

# Atlantis the lost world?...

1/32nd scale metal models



A33 'Grossenwulf' King of Thorea

A35 Old Witch 'Zolda'

A36 'Ogash'

A34 Seated Girl Captive

A37 Female Thorean Guard



**PHOENIX MODEL DEVELOPMENTS LTD.**

EARLS BARTON, NORTHAMPTON NN6 0NA ENGLAND Tel: NORTHAMPTON 810612

**NEW CATALOGUE**  
NEW 1981 EDITION  
U.K. \$1.00 (U.S.A. \$2.50 (airmail))  
OVERSEAS GENERALLY \$1.80

# COLLECTABLES



Continuing with Citadel we see their marvelous originality in peopling their gaming figures with families including wives and children as well as weird beasts and humanoids and dungeon accessories.



Some things are as elusive  
as unicorns,  
Other things only seem that way!  
At  
**STRATEGY & FANTASY  
WORLD**

We specialize in locating  
what other stores never even  
know about!

BALTIMORE, M.D. • 8 West 25th St. at Charles  
(301-366-1665) BOSTON, MA • 201 Massachusetts  
Ave. (617-267-2451) CLEVELAND, OH. • Colonial  
Arcade, 530 Euclid Ave. (216-621-2293) FALLS  
CHURCH, VA • 103 East Broad St. (703-532-2477)  
KING OF PRUSSIA, PA • Valley Forge Shopping  
Center, 254 W. DeKalb Pike (215-265-8562)  
PHILADELPHIA, PA • 2011 Walnut St.  
(215-563-2960)

Ask about our 1981 Bonus Book Program!

# BOOK REVIEWS

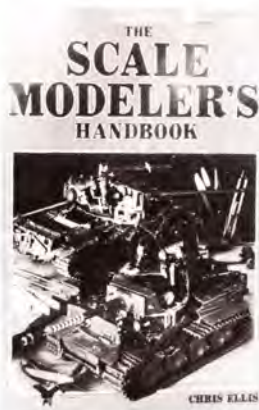

A lot of mail crosses our desks at *FANTASY MODELING* from readers asking: How can I paint miniatures like the ones in your magazine? A very simple answer is: 1. You're a great natural talent and anything you do with a brush is perfect (and before you know it photos of your stuff will be gracing our pages). 2. A great miniaturist lives in your neighborhood and he's willing to make you his apprentice. He critiques your work, and teaches you all he's learned over his lifetime. 3. You buy yourself some paints, some brushes, and some figures. Like Thomas Edison using the trial-and-error method, you discover how to achieve many of these effects. 4. You buy one of the many books on the market that discloses a lot of the secrets of the pros and also show you how to improve your work. With the growing interest in painting miniatures, there have been quite a few of these how-to books released.

**THE VERLINDEN WAY Vol. 1** (F. Verlinden Publications, 13 Berlaarsestraat, Lier 2500, Belgium. Suggested retail: \$10.95.) Verlinden is an acknowledged master of plastic military equipment painting and detailing. Unfortunately, this book is *only* for the most experienced painters. There are only five pages of technique. Exquisite examples of complete dioramas decorate the rest of this soft-covered book. The excellent photos display good ideas, but the lack of text leaves us wanting explanations on how to achieve these effects.

On the other hand, a beginner or even an experienced painter would be able to make use of **THE SCALE MODELER'S HANDBOOK** by Chris Ellis. (Chartwell Books, Book Sales Inc., 110 Enterprise Avenue, Seacaucus, New Jersey. Retail: \$8.98.) This hard-cover book runs over 200 pages and covers just about every topic a modeler might be interested in. As I said, it is designed for beginners so it starts at the

most elemental level—which kit and what model? Tools, materials, adhesives, airbrushing, markings, dioramas, photography, are some of the topics covered in this book. It offers a wealth of material both in text and in the many different types of photos. Most important, it explains how to achieve these impressive effects. Though it may not have as many color photos as the Verlinden book, the photos it does have are more useful. So, if you've eliminated both No. 1 and No. 2 on my list for improving your painting, perhaps you should look into these two books or others like them.

By Mike Kilbert

**TALES OF GREAT DRAGONS** by J.K. Anderson, Bellerophon Books, 36 Anacapa Street, Santa Barbara CA 93101. Price \$3.50.

Written by the professor of classical archeology at the University of California this book covers all of the dragons created in art from ancient times to the late Middle Ages. It is essentially an illustrated coloring book for the young but at the same time it covers all aspects of archeological representation through the Middle East and Europe. Surrounding each creature are the legends and stories of its existence and character. The names of some of these imagined dragons are filled with romantic color; Tiamat, Faridum, Draco, Grendel, Melusine, to name a few. Throughout the world the legends tell of good and bad dragons, but seldom have they been portrayed in one book quite as effectively and with such imaginative illustrations. We have all heard of St. George and the dragon and certainly have seen many paintings of this knight rescuing the fair maiden from its clutches, but never before has our focus been brought to bear on almost every aspect of dragonly creation than in this beautifully presented book. ▲

By Philip O. Stearns

**YOU ASKED FOR IT! FLOQUIL AEROSOL MA9 FIGURE PRIMER**

For metal figures and miniatures of all types.

Now you can spray on a smooth, even coat of primer that dries skin-tight without plugging or obscuring the fine casting detail of your miniature.

High adherence coating provides an excellent bond to metal and is resistant to chipping or flaking. Velvety flat finish provides just enough "tooth" to make miniatures easier to paint and detail.

This neutral light gray color covers easily and is the perfect base coat for all water-based or solvent based paints.

From start to finish — depend on Floquil-Polly S to finish your fine miniatures.

**MA9 Figure-Primer**  
5oz. can \$2.98



**Floquil-Polly S Color Corp.**  
Route 30 North  
Amsterdam, New York 12010

AN RPM COMPANY



## FANTASY MODELING BACK ISSUES

DEPT. FM4  
475 Park Avenue South,  
New York, NY 10016

\_\_\_ #1—\$4.00 Postage & Handling:  
\_\_\_ #2—\$3.00 1 Magazine: add \$ .80  
First Class Postage  
2 Magazines: add \$1.06  
First Class Postage

Only U.S., Australia and New Zealand funds accepted.  
Note: If you don't want to cut up this magazine, please print your order on a separate piece of paper.

NAME \_\_\_\_\_  
ADDRESS \_\_\_\_\_  
CITY \_\_\_\_\_  
STATE \_\_\_\_\_ ZIP \_\_\_\_\_

## Capacitating Caps

Of all the "discarded" objects, or just plain junk, that can be incorporated into scratch built science fiction models, plastic bottle caps are some of the most plentiful around the home. They are under your sink, in the bathroom and in the medicine chest. Bottle caps come in a vast array of shapes and sizes, and the clever modeler can work them into all sorts of designs. If he pays attention to the details found *inside* the caps, the modeler can come up with bits and pieces that will defy recognition.

Rocket nozzles are an obvious use for bottle caps. Photo 1 shows the rear end of a small spacecraft and a couple of the components that went into it. Two dish washing liquid caps (1a) with the stoppers removed became the exhausts. Note the detail molded into the rim! The segmented pieces inside the caps were cut from a spool (1b) from a roll of adding machine paper.

Details around the base of the nozzles are various model car parts, including the *back sides* of some wheel covers. The ribbed strips along the spacecraft hull came from the handles of a couple of disposable razors (the same type shown in last issue's Odds & Ends).

The collection of parts in Photo 2 includes a few bottle caps that were used in various ways.

There is some interesting detail inside the caps found on *Downy* fabric softener, and just a ring from the center of the cap (2a) was used here to form the wall of an equipment well. Only the bottom edge of a shampoo cap (2b), with its ratchet-like detail, was needed to make the track centered in that well.

Bottle caps can be disguised, and additional shapes created, by cutting the caps at different angles, as in this projecting base (2h) for a radar tower.

The radar assembly itself is composed of a few other easy to find objects. The tower is a push-pin (2g), and the swivel joint is a large map-tack (2e). (Smaller map-tacks form the row of spherical tanks). Half of a decorative plastic bead (2f) found in the arts and crafts store form the radar dish itself.

Of course, kit components almost always work their way into scratch built spaceship detail, and they must be disguised to obscure their origin.

The piece of equipment in the bottle cap well is made up of the seats from two halves of a miniature cable car kit. The roof and end platforms were cut away, and the two seats were jointed bottom-to-bottom (2c). The Center section of a small hovercraft model (2d) provided the detail in the area below the equipment well. △

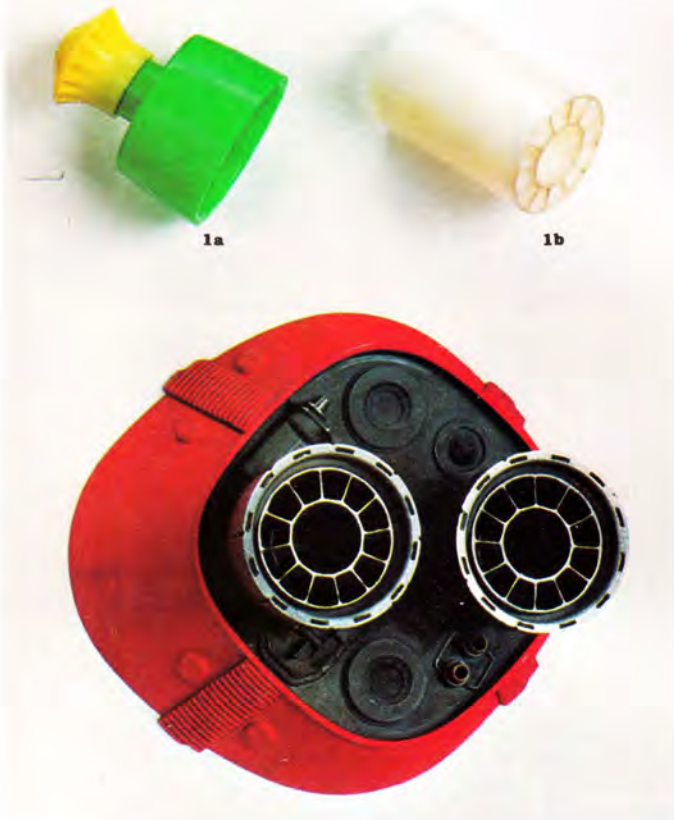

LAST CHANCE AT THIS PRICE!!

# FANTASY Modeling

PREMIERE ISSUE

Wargames—The Greatest Fantasy of Them All!

Kitbashing Spaceships

The Popular Imagery of Boris Vallejo

The Plastic Industry Strikes Back!

Atlantis—No Longer a Lost Continent



At last . . . a professional, full-color magazine that covers everything in the wonderful world of modeling!

## FANTASY FIGURES

From magnificent heroes and sexy heroines to dragons and elves and dinosaurs and all the other incredible creatures of fantasy, here are color photos galore in each exciting issue.

## MILITARY MODELS

Experts of the field have called military models the greatest fantasy of all—here are colorful troops of all ages in history—famous warriors in full regalia—powerful horses, scenes of battle and action.



## CREATING DIORAMAS

Fantastic miniature settings for fantasy figures—how to assemble ornate furniture, props, painted backgrounds, and special lighting for dramatic effects.

## COLLECTIONS

A look into the private showcases of serious collectors—rare and wonderful items that have been accumulated and preserved over the years.

## MODEL KITS

From plastic to metal, each issue includes information on the most outstanding manufactured kits available—their faults, behind-the-scenes looks at their making, and the best examples of assembly-line models.

## MAKING SPACESHIPS

Science fiction hardware, one of the most popular branches of fantasy modeling, explored in each issue in vivid, detailed color photos and step-by-step construction pictures.



## KIT BASHING & SCRATCH BUILDING

The two most popular methods of model building—the creative differences between them—some incredible examples of each approach in every issue.

**NOT AVAILABLE AT NEWSSTANDS  
SUBSCRIBE TODAY AND SAVE!!!  
(Regular cover price: \$2.50 per issue)**

## GAMING

This aspect of fantasy modeling is a growing new excitement around the world—professional war games, board games, electronic games, participation games and all sorts of wild, wonderful fantasy games that have been invented and produced by local fans and companies.

## BOOKS

A review of valuable publications which you ought to have on your library shelf—books about modeling, fantasy and science fiction art, interesting related topics.

Send cash, check or money order to:

DEPT. FM4

**FANTASY MODELING 475 Park Ave. South New York, NY 10016**

Yes, at last I can subscribe to a magazine that covers everything in the wonderful world of modeling.

One Year \$9.99  
(four quarterly issues)  
U.S. and Canada

Foreign \$12.39  
(surface mail)

NAME

ADDRESS

CITY

STATE

ZIP

Please allow 4 to 8 weeks for delivery of first issue.

**Satisfaction Guaranteed!**

# NEW STARLOG photo guidebooks

Latest Releases

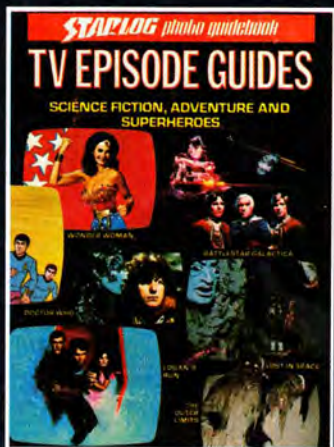

## TV EPISODE GUIDES

Science Fiction, Adventure and Superheroes \$7.95, 96 pages  
A complete listing of 12 fabulous science fiction, adventure or superhero series. Each chapter includes (a) complete plot synopses (b) cast and crew lists. (c) dozens of rare photos, many in FULL COLOR



## TOYS & MODELS

\$3.95, 34 Pages (Available October)  
A photo-filled guide to the fantastic world of toys and games. There's everything from Buck Rogers rocket skates to a mini Robby the Robot! Full-color photos showcase collections spanning four generations.



## SPACESHIPS

(new enlarged edition) \$7.95, 96 pages  
The most popular book in this series has been expanded to three times the pages and updated with dozens of new photos from every movie and TV show that features spaceships—the dream machines! Many in full color.



## HEROES

\$3.95, 34 pages  
From Flash Gordon to Luke Skywalker, here is a thrilling photo scrapbook of the most shining heroes in science-fiction movies, TV and literature. Biographies of the men and women who inspire us and bring triumphant cheers from audiences.

### All Books In This Special Series

- Quality high-gloss paper.
- Big 8 1/4"x11" page format.
- Rare photos and valuable reference data.
- A must for every science fiction library!
- Available at Waldenbooks, B. Dalton Booksellers and other fine bookstores. Or order directly, using the coupon below.



VILLAINS, \$3.95  
34 pages, full color throughout

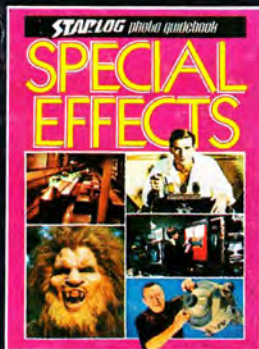

SPECIAL EFFECTS, VOL. II  
\$7.95, 96 pages



SPACESHIPS \$2.95  
34 pages, over 100 photos

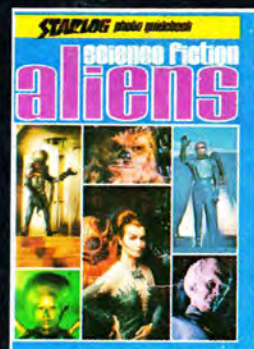

ALIENS \$7.95  
96 pages, over 200 photos

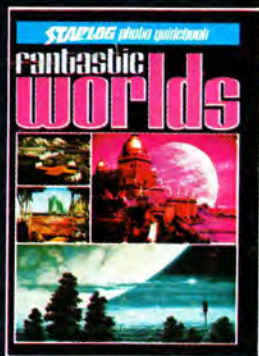

FANTASTIC WORLDS \$7.95  
96 pages, over 200 photos



SPACE ART \$8.95  
(\$13 for deluxe)  
196 pages, full color throughout

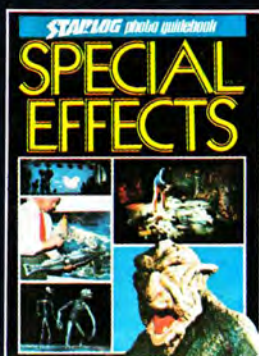

SPECIAL EFFECTS, VOL. I \$6.95  
96 pages, full color throughout

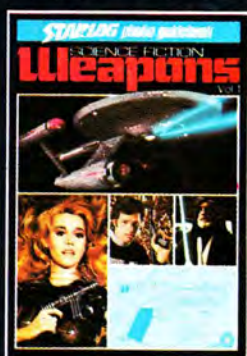

SCIENCE FICTION WEAPONS \$3.95  
34 pages, full color throughout



ROBOTS \$7.95  
96 pages, full color throughout

Add postage to your order:

HEROES ..... \$3.95  
VILLAINS ..... \$3.95  
SPACESHIPS I ..... \$3.95  
WEAPONS ..... \$3.95  
TOYS & MODELS ..... \$3.95  
Prices for all of the above:  
\_\_\_ 3rd Class ..... \$1.00 ea.  
\_\_\_ 1st Class ..... \$1.25 ea.  
\_\_\_ Foreign Air ..... \$2.25 ea.

SPACESHIPS (new enlarged) ..... \$7.95  
SPECIAL EFFECTS VOL. II ..... \$7.95  
TV EPISODE GUIDE BOOK ..... \$7.95  
ALIENS ..... \$7.95  
FANTASTIC WORLDS ..... \$7.95  
ROBOTS ..... \$7.95  
Prices for all of the above:  
\_\_\_ 3rd Class ..... \$1.75  
\_\_\_ 1st Class ..... \$1.55  
\_\_\_ Foreign Air ..... \$2.50

SPECIAL EFFECTS ..... \$6.95  
\_\_\_ 3rd Class ..... \$1.50  
\_\_\_ 1st Class ..... \$2.00  
\_\_\_ Foreign Air ..... \$5.50  
SPACE ART ..... \$8.95  
Regular Edition ..... \$8.95  
Deluxe Edition ..... \$13.00  
U.S. Book rates  
\$2.00 ea.  
\_\_\_ U.S. Priority ..... \$2.57 reg  
\$3.30 deluxe  
\_\_\_ Foreign Air ..... \$7.00 reg  
\$8.50 deluxe

Send to:  
STARLOG GUIDEBOOKS  
DEPT. FM4  
475 Park Avenue South  
New York, NY 10016

total enclosed: \$ \_\_\_\_\_  
NYS residents add sales tax  
Please allow 4 to 6 weeks for delivery of 3rd Class mail. First Class delivery usually takes 2 to 3 weeks.

Name \_\_\_\_\_

Address \_\_\_\_\_

City \_\_\_\_\_

State \_\_\_\_\_ Zip \_\_\_\_\_

ONLY U.S., Australia and New Zealand funds accepted.  
Dealers: Inquire for wholesale rates on Photo Guidebooks.  
NOTE: Don't want to cut coupon? Write order on separate piece of paper.